

EXAMINED BY : Justin Horng	EMERGING DISPLAY TECHNOLOGIES CORPORATION	FILE NO . CAS-0006514
APPROVED BY: Yung Chang Hu		ISSUE : AUG.12, 2014
		TOTAL PAGE : 23
		VERSION : 5

CUSTOMER ACCEPTANCE SPECIFICATIONS

MODEL NO. :
ET057010DMU
 (RoHS)
 FOR MESSRS :

CUSTOMER'S APPROVAL

DATE : _____

BY : _____

RECORDS OF REVISION	DOC . FIRST ISSUE	OCT.30, 2007
---------------------	-------------------	--------------

DATE	REVISED PAGE NO.	SUMMARY																																																																																																																																														
JAN.08, 2008	1	<p>2. MECHANICAL SPECIFICATIONS</p> <p>(1) DISPLAY SIZE (inch) -----5.7" → DIAGONALS ----- 5.7 inch</p> <p>(3) MODULE SIZE ----- 124.7W*100.0H*10.5D mm (WITHOUT FPC)→</p> <p>(3) MODULE SIZE ----- 124.7W*100.0H*10.8D (MAX) mm (WITHOUT FPC)</p> <p>(5) ACTIVE AREA ----- 115.2W * 86.4H mm(LCD) →115.2W * 86.4H mm</p> <p>(9) COLOR ----- 16.7M (24BIT) →16.7M</p> <p>ADD (12)</p>																																																																																																																																														
	2	<p>3.1 ELECTRICAL ABSOLUTE MAXIMUM RATINGS</p> <table border="1"> <thead> <tr> <th>PARAMETER</th> <th>SYMBOL</th> <th>MIN.</th> <th>MAX.</th> <th>UNIT</th> <th>REMARK</th> </tr> </thead> <tbody> <tr> <td rowspan="2">POWER SUPPLY VOLTAGE</td> <td>VCC</td> <td>-0.3</td> <td>7.0</td> <td>V</td> <td>VSS=0</td> </tr> <tr> <td>VDD</td> <td>-0.3</td> <td>7.0</td> <td>V</td> <td></td> </tr> </tbody> </table> <p style="text-align: center;">↓</p> <table border="1"> <thead> <tr> <th>PARAMETER</th> <th>SYMBOL</th> <th>MIN.</th> <th>MAX.</th> <th>UNIT</th> <th>REMARK</th> </tr> </thead> <tbody> <tr> <td rowspan="2">POWER SUPPLY VOLTAGE</td> <td>VCC</td> <td>-0.3</td> <td>7.0</td> <td>V</td> <td>VSS=0V</td> </tr> <tr> <td>VDD</td> <td>-0.3</td> <td>7.0</td> <td>V</td> <td></td> </tr> </tbody> </table>	PARAMETER	SYMBOL	MIN.	MAX.	UNIT	REMARK	POWER SUPPLY VOLTAGE	VCC	-0.3	7.0	V	VSS=0	VDD	-0.3	7.0	V		PARAMETER	SYMBOL	MIN.	MAX.	UNIT	REMARK	POWER SUPPLY VOLTAGE	VCC	-0.3	7.0	V	VSS=0V	VDD	-0.3	7.0	V																																																																																																													
PARAMETER	SYMBOL	MIN.	MAX.	UNIT	REMARK																																																																																																																																											
POWER SUPPLY VOLTAGE	VCC	-0.3	7.0	V	VSS=0																																																																																																																																											
	VDD	-0.3	7.0	V																																																																																																																																												
PARAMETER	SYMBOL	MIN.	MAX.	UNIT	REMARK																																																																																																																																											
POWER SUPPLY VOLTAGE	VCC	-0.3	7.0	V	VSS=0V																																																																																																																																											
	VDD	-0.3	7.0	V																																																																																																																																												
	3	<p>4. ELECTRICAL CHARACTERISTICS</p> <table border="1"> <thead> <tr> <th>PARAMETER</th> <th>SYMBOL</th> <th>CONDITION</th> <th>MIN.</th> <th>TYP.</th> <th>MAX.</th> <th>UNIT</th> <th>REMARK</th> </tr> </thead> <tbody> <tr> <td>POWER SUPPLY CURRENT FOR VCOM</td> <td>IDD</td> <td>VDD = 3.3V</td> <td>—</td> <td>(510)</td> <td>(600)</td> <td>mA</td> <td></td> </tr> <tr> <td>POWER SUPPLY CURRENT FOR LCD</td> <td>ICC</td> <td>VCC = 3.3V LED B/L = ON</td> <td>—</td> <td>(8)</td> <td>(12)</td> <td>mA</td> <td></td> </tr> <tr> <td>FORWARD VOLTAGE</td> <td>V_F</td> <td>I_F=40mA</td> <td>28</td> <td>30</td> <td>32</td> <td>V</td> <td>NOTE(1)</td> </tr> </tbody> </table> <p style="text-align: center;">↓</p> <table border="1"> <thead> <tr> <th>PARAMETER</th> <th>SYMBOL</th> <th>CONDITION</th> <th>MIN.</th> <th>TYP.</th> <th>MAX.</th> <th>UNIT</th> <th>REMARK</th> </tr> </thead> <tbody> <tr> <td>POWER SUPPLY CURRENT FOR VCOM</td> <td>IDD</td> <td>VDD = 3.3V LED B/L = ON</td> <td>—</td> <td>510</td> <td>600</td> <td>mA</td> <td></td> </tr> <tr> <td>POWER SUPPLY CURRENT FOR LCD</td> <td>ICC</td> <td>VCC = 3.3V</td> <td>—</td> <td>8</td> <td>12</td> <td>mA</td> <td></td> </tr> <tr> <td>LED BACKLIGHT FORWARD VOLTAGE</td> <td>V_F</td> <td>I_F=40mA</td> <td>28</td> <td>30</td> <td>32</td> <td>V</td> <td>NOTE(1)</td> </tr> </tbody> </table> <p>ADD NOTE(2)</p>	PARAMETER	SYMBOL	CONDITION	MIN.	TYP.	MAX.	UNIT	REMARK	POWER SUPPLY CURRENT FOR VCOM	IDD	VDD = 3.3V	—	(510)	(600)	mA		POWER SUPPLY CURRENT FOR LCD	ICC	VCC = 3.3V LED B/L = ON	—	(8)	(12)	mA		FORWARD VOLTAGE	V _F	I _F =40mA	28	30	32	V	NOTE(1)	PARAMETER	SYMBOL	CONDITION	MIN.	TYP.	MAX.	UNIT	REMARK	POWER SUPPLY CURRENT FOR VCOM	IDD	VDD = 3.3V LED B/L = ON	—	510	600	mA		POWER SUPPLY CURRENT FOR LCD	ICC	VCC = 3.3V	—	8	12	mA		LED BACKLIGHT FORWARD VOLTAGE	V _F	I _F =40mA	28	30	32	V	NOTE(1)																																																																														
PARAMETER	SYMBOL	CONDITION	MIN.	TYP.	MAX.	UNIT	REMARK																																																																																																																																									
POWER SUPPLY CURRENT FOR VCOM	IDD	VDD = 3.3V	—	(510)	(600)	mA																																																																																																																																										
POWER SUPPLY CURRENT FOR LCD	ICC	VCC = 3.3V LED B/L = ON	—	(8)	(12)	mA																																																																																																																																										
FORWARD VOLTAGE	V _F	I _F =40mA	28	30	32	V	NOTE(1)																																																																																																																																									
PARAMETER	SYMBOL	CONDITION	MIN.	TYP.	MAX.	UNIT	REMARK																																																																																																																																									
POWER SUPPLY CURRENT FOR VCOM	IDD	VDD = 3.3V LED B/L = ON	—	510	600	mA																																																																																																																																										
POWER SUPPLY CURRENT FOR LCD	ICC	VCC = 3.3V	—	8	12	mA																																																																																																																																										
LED BACKLIGHT FORWARD VOLTAGE	V _F	I _F =40mA	28	30	32	V	NOTE(1)																																																																																																																																									
	6	<p>6.1 OPTICAL CHARACTERISTICS</p> <table border="1"> <thead> <tr> <th>ITEM</th> <th>SYMBOL</th> <th>CONDITION</th> <th>MIN.</th> <th>TYP.</th> <th>MAX.</th> <th>UNIT</th> <th>REMARK</th> </tr> </thead> <tbody> <tr> <td rowspan="2">RESPONSE TIME</td> <td>t_r (rise)</td> <td>0x=0°, 0y=0°</td> <td>—</td> <td>15</td> <td>30</td> <td>msec</td> <td>(4)</td> </tr> <tr> <td>t_f (fall)</td> <td>0x=0°, 0y=0°</td> <td>—</td> <td>35</td> <td>50</td> <td>msec</td> <td></td> </tr> <tr> <td rowspan="6">COLOR OF CIE COORDINATE</td> <td>WHITE</td> <td rowspan="6">0x=0°, 0y=0° IF = 40mA NTSC : 50 %</td> <td>x</td> <td>0.26</td> <td>0.31</td> <td>0.26</td> <td rowspan="6">(6)</td> </tr> <tr> <td>y</td> <td>0.30</td> <td>0.35</td> <td>0.40</td> </tr> <tr> <td>RED</td> <td>x</td> <td>0.56</td> <td>0.61</td> <td>0.66</td> </tr> <tr> <td>y</td> <td>0.31</td> <td>0.36</td> <td>0.41</td> </tr> <tr> <td>GREEN</td> <td>x</td> <td>0.28</td> <td>0.33</td> <td>0.38</td> </tr> <tr> <td>y</td> <td>0.51</td> <td>0.56</td> <td>0.61</td> </tr> <tr> <td rowspan="2">BLUE</td> <td>x</td> <td>0.09</td> <td>0.14</td> <td>0.19</td> <td rowspan="2"></td> </tr> <tr> <td>y</td> <td>0.07</td> <td>0.12</td> <td>0.17</td> </tr> <tr> <td>THE UNIFORMITY OF MODULE</td> <td>—</td> <td>—</td> <td>75</td> <td>80</td> <td>—</td> <td>%</td> <td>—</td> </tr> </tbody> </table> <p style="text-align: center;">↓</p> <table border="1"> <thead> <tr> <th>ITEM</th> <th>SYMBOL</th> <th>CONDITION</th> <th>MIN.</th> <th>TYP.</th> <th>MAX.</th> <th>UNIT</th> <th>REMARK</th> </tr> </thead> <tbody> <tr> <td rowspan="2">RESPONSE TIME</td> <td>t_r (rise)</td> <td>0x=0°, 0y=0°</td> <td>—</td> <td>15</td> <td>30</td> <td>msec</td> <td>(4)</td> </tr> <tr> <td>t_f (fall)</td> <td>0x=0°, 0y=0°</td> <td>—</td> <td>35</td> <td>50</td> <td>msec</td> <td></td> </tr> <tr> <td rowspan="6">COLOR OF CIE COORDINATE</td> <td>WHITE</td> <td rowspan="6">0x=0°, 0y=0° IF = 40mA NTSC : 50 %</td> <td>w_x</td> <td>0.26</td> <td>0.31</td> <td>0.26</td> <td rowspan="6">(6)</td> </tr> <tr> <td>y</td> <td>0.30</td> <td>0.35</td> <td>0.40</td> </tr> <tr> <td>RED</td> <td>r_x</td> <td>0.56</td> <td>0.61</td> <td>0.66</td> </tr> <tr> <td>y</td> <td>0.31</td> <td>0.36</td> <td>0.41</td> </tr> <tr> <td>GREEN</td> <td>g_x</td> <td>0.28</td> <td>0.33</td> <td>0.38</td> </tr> <tr> <td>y</td> <td>0.51</td> <td>0.56</td> <td>0.61</td> </tr> <tr> <td rowspan="2">BLUE</td> <td>b_x</td> <td>0.09</td> <td>0.14</td> <td>0.19</td> <td rowspan="2"></td> </tr> <tr> <td>y</td> <td>0.07</td> <td>0.12</td> <td>0.17</td> </tr> <tr> <td>THE UNIFORMITY OF MODULE</td> <td>—</td> <td>IF=40mA</td> <td>75</td> <td>80</td> <td>—</td> <td>%</td> <td>—</td> </tr> </tbody> </table>	ITEM	SYMBOL	CONDITION	MIN.	TYP.	MAX.	UNIT	REMARK	RESPONSE TIME	t _r (rise)	0x=0°, 0y=0°	—	15	30	msec	(4)	t _f (fall)	0x=0°, 0y=0°	—	35	50	msec		COLOR OF CIE COORDINATE	WHITE	0x=0°, 0y=0° IF = 40mA NTSC : 50 %	x	0.26	0.31	0.26	(6)	y	0.30	0.35	0.40	RED	x	0.56	0.61	0.66	y	0.31	0.36	0.41	GREEN	x	0.28	0.33	0.38	y	0.51	0.56	0.61	BLUE	x	0.09	0.14	0.19		y	0.07	0.12	0.17	THE UNIFORMITY OF MODULE	—	—	75	80	—	%	—	ITEM	SYMBOL	CONDITION	MIN.	TYP.	MAX.	UNIT	REMARK	RESPONSE TIME	t _r (rise)	0x=0°, 0y=0°	—	15	30	msec	(4)	t _f (fall)	0x=0°, 0y=0°	—	35	50	msec		COLOR OF CIE COORDINATE	WHITE	0x=0°, 0y=0° IF = 40mA NTSC : 50 %	w _x	0.26	0.31	0.26	(6)	y	0.30	0.35	0.40	RED	r _x	0.56	0.61	0.66	y	0.31	0.36	0.41	GREEN	g _x	0.28	0.33	0.38	y	0.51	0.56	0.61	BLUE	b _x	0.09	0.14	0.19		y	0.07	0.12	0.17	THE UNIFORMITY OF MODULE	—	IF=40mA	75	80	—	%	—
ITEM	SYMBOL	CONDITION	MIN.	TYP.	MAX.	UNIT	REMARK																																																																																																																																									
RESPONSE TIME	t _r (rise)	0x=0°, 0y=0°	—	15	30	msec	(4)																																																																																																																																									
	t _f (fall)	0x=0°, 0y=0°	—	35	50	msec																																																																																																																																										
COLOR OF CIE COORDINATE	WHITE	0x=0°, 0y=0° IF = 40mA NTSC : 50 %	x	0.26	0.31	0.26	(6)																																																																																																																																									
	y		0.30	0.35	0.40																																																																																																																																											
	RED		x	0.56	0.61	0.66																																																																																																																																										
	y		0.31	0.36	0.41																																																																																																																																											
	GREEN		x	0.28	0.33	0.38																																																																																																																																										
	y		0.51	0.56	0.61																																																																																																																																											
BLUE	x	0.09	0.14	0.19																																																																																																																																												
	y	0.07	0.12	0.17																																																																																																																																												
THE UNIFORMITY OF MODULE	—	—	75	80	—	%	—																																																																																																																																									
ITEM	SYMBOL	CONDITION	MIN.	TYP.	MAX.	UNIT	REMARK																																																																																																																																									
RESPONSE TIME	t _r (rise)	0x=0°, 0y=0°	—	15	30	msec	(4)																																																																																																																																									
	t _f (fall)	0x=0°, 0y=0°	—	35	50	msec																																																																																																																																										
COLOR OF CIE COORDINATE	WHITE	0x=0°, 0y=0° IF = 40mA NTSC : 50 %	w _x	0.26	0.31	0.26	(6)																																																																																																																																									
	y		0.30	0.35	0.40																																																																																																																																											
	RED		r _x	0.56	0.61	0.66																																																																																																																																										
	y		0.31	0.36	0.41																																																																																																																																											
	GREEN		g _x	0.28	0.33	0.38																																																																																																																																										
	y		0.51	0.56	0.61																																																																																																																																											
BLUE	b _x	0.09	0.14	0.19																																																																																																																																												
	y	0.07	0.12	0.17																																																																																																																																												
THE UNIFORMITY OF MODULE	—	IF=40mA	75	80	—	%	—																																																																																																																																									
	7	<p>6.2 THE TEST METHOD OF BRIGHTNESS AND UNIFORMITY</p>																																																																																																																																														
	8	<p>7. OUTLINE DIMENSIONS</p> <p>MARK Δ :ADDING DIMENSION & MODIFY PCB OUTLINE</p>																																																																																																																																														
	9	<p>8. BLOCK DIAGRAM</p> <p>UPDATE BLOCK BLOCK DIAGRAM</p>																																																																																																																																														

DOC . FIRST ISSUE

RECORDS OF REVISION

OCT.30, 2007

DATE	REVISED PAGE NO.	SUMMARY																																																																																
	13	<p>11.1 POWER SUPPLY FOR LCM</p> <p>ADD 11.2 THE BRIGHTNESS CONTROLLED BY PWM SIGNAL OF LEDCTRL</p>																																																																																
	14~23	<p>12.3 INSPECTION CRITERION INSPECTION CRITERION MODIFIED</p>																																																																																
APR.22,2008	3	<p>4 . ELECTRICAL CHARACTERISTICS</p> <table border="1"> <thead> <tr> <th>PARAMETER</th> <th>SYMBOL</th> <th>CONDITION</th> <th>MIN.</th> <th>TYP.</th> <th>MAX.</th> <th>UNIT</th> <th>REMARK</th> </tr> </thead> <tbody> <tr> <td>POWER SUPPLY VOLTAGE FOR VCOM</td> <td>VDD</td> <td>—</td> <td>1.2</td> <td>1.2</td> <td>1.2</td> <td>V</td> <td></td> </tr> <tr> <td>POWER SUPPLY VOLTAGE FOR LED</td> <td>VCC</td> <td>—</td> <td>1.2</td> <td>1.2</td> <td>1.2</td> <td>V</td> <td></td> </tr> <tr> <td>POWER SUPPLY CURRENT FOR VCOM</td> <td>I_{DD}</td> <td>VDD=1.2V</td> <td>—</td> <td>110</td> <td>600</td> <td>μA</td> <td></td> </tr> <tr> <td>POWER SUPPLY CURRENT FOR LED</td> <td>I_{CC}</td> <td>VCC=1.2V</td> <td>—</td> <td>15</td> <td>12</td> <td>mA</td> <td></td> </tr> </tbody> </table> <table border="1"> <thead> <tr> <th>PARAMETER</th> <th>SYMBOL</th> <th>CONDITION</th> <th>MIN.</th> <th>TYP.</th> <th>MAX.</th> <th>UNIT</th> <th>REMARK</th> </tr> </thead> <tbody> <tr> <td>POWER SUPPLY VOLTAGE FOR VCOM</td> <td>VDD</td> <td>—</td> <td>1.2</td> <td>1.2</td> <td>1.2</td> <td>V</td> <td></td> </tr> <tr> <td>POWER SUPPLY VOLTAGE FOR LED</td> <td>VCC</td> <td>—</td> <td>1.2</td> <td>1.2</td> <td>1.2</td> <td>V</td> <td></td> </tr> <tr> <td>POWER SUPPLY CURRENT FOR VCOM</td> <td>I_{DD}</td> <td>VDD=1.2V</td> <td>—</td> <td>110</td> <td>600</td> <td>μA</td> <td></td> </tr> <tr> <td>POWER SUPPLY CURRENT FOR LED</td> <td>I_{CC}</td> <td>VCC=1.2V</td> <td>—</td> <td>15</td> <td>12</td> <td>mA</td> <td></td> </tr> </tbody> </table>	PARAMETER	SYMBOL	CONDITION	MIN.	TYP.	MAX.	UNIT	REMARK	POWER SUPPLY VOLTAGE FOR VCOM	VDD	—	1.2	1.2	1.2	V		POWER SUPPLY VOLTAGE FOR LED	VCC	—	1.2	1.2	1.2	V		POWER SUPPLY CURRENT FOR VCOM	I _{DD}	VDD=1.2V	—	110	600	μA		POWER SUPPLY CURRENT FOR LED	I _{CC}	VCC=1.2V	—	15	12	mA		PARAMETER	SYMBOL	CONDITION	MIN.	TYP.	MAX.	UNIT	REMARK	POWER SUPPLY VOLTAGE FOR VCOM	VDD	—	1.2	1.2	1.2	V		POWER SUPPLY VOLTAGE FOR LED	VCC	—	1.2	1.2	1.2	V		POWER SUPPLY CURRENT FOR VCOM	I _{DD}	VDD=1.2V	—	110	600	μA		POWER SUPPLY CURRENT FOR LED	I _{CC}	VCC=1.2V	—	15	12	mA	
PARAMETER	SYMBOL	CONDITION	MIN.	TYP.	MAX.	UNIT	REMARK																																																																											
POWER SUPPLY VOLTAGE FOR VCOM	VDD	—	1.2	1.2	1.2	V																																																																												
POWER SUPPLY VOLTAGE FOR LED	VCC	—	1.2	1.2	1.2	V																																																																												
POWER SUPPLY CURRENT FOR VCOM	I _{DD}	VDD=1.2V	—	110	600	μA																																																																												
POWER SUPPLY CURRENT FOR LED	I _{CC}	VCC=1.2V	—	15	12	mA																																																																												
PARAMETER	SYMBOL	CONDITION	MIN.	TYP.	MAX.	UNIT	REMARK																																																																											
POWER SUPPLY VOLTAGE FOR VCOM	VDD	—	1.2	1.2	1.2	V																																																																												
POWER SUPPLY VOLTAGE FOR LED	VCC	—	1.2	1.2	1.2	V																																																																												
POWER SUPPLY CURRENT FOR VCOM	I _{DD}	VDD=1.2V	—	110	600	μA																																																																												
POWER SUPPLY CURRENT FOR LED	I _{CC}	VCC=1.2V	—	15	12	mA																																																																												
	6	<p>6.1 OPTICAL CHARACTERISTICS NOTE (1) : TEST EQUIPMENT SETUP : 2°→1°</p>																																																																																
	8	<p>7 . OUTLINE DIMENSIONS MARK △ : ADD NOTE</p>																																																																																
	11~12	<p>10. INTERFACE SIGNALS</p> <table border="1"> <thead> <tr> <th>PIN NO</th> <th>SYMBOL</th> <th>LED</th> <th>FUNCTION</th> </tr> </thead> <tbody> <tr> <td>5</td> <td>VDD</td> <td>P</td> <td>POWER SUPPLY FOR VCOM DRIVER CIRCUIT</td> </tr> <tr> <td>6</td> <td>VDD</td> <td>P</td> <td>POWER SUPPLY FOR VCOM DRIVER CIRCUIT</td> </tr> <tr> <td>9</td> <td>ENB</td> <td>I</td> <td>DATA ENABLE INPUT</td> </tr> <tr> <td>10</td> <td>VSYNC</td> <td>I</td> <td>VERTICAL SYNC INPUT</td> </tr> <tr> <td>11</td> <td>HSYNC</td> <td>I</td> <td>HORIZONTAL SYNC INPUT</td> </tr> <tr> <td>40</td> <td>VCC</td> <td>P</td> <td>POWER SUPPLY FOR DIGITAL CIRCUIT</td> </tr> </tbody> </table> <table border="1"> <thead> <tr> <th>PIN NO</th> <th>SYMBOL</th> <th>LED</th> <th>FUNCTION</th> </tr> </thead> <tbody> <tr> <td>5</td> <td>VDD</td> <td>P</td> <td>POWER SUPPLY FOR DIGITAL CIRCUIT</td> </tr> <tr> <td>6</td> <td>VDD</td> <td>P</td> <td>POWER SUPPLY FOR DIGITAL CIRCUIT</td> </tr> <tr> <td>9</td> <td>ENB</td> <td>I</td> <td>DATA ENABLE INPUT DE MODE & SYNC MODE SETTING DE MODE : ONLY ENB AND PDEL CLOCK IS NECESSARY.</td> </tr> <tr> <td>10</td> <td>VSYNC</td> <td>I</td> <td>VERTICAL SYNC INPUT SYNC MODE : ENB SHOULD BE CONNECTED TO VSS.</td> </tr> <tr> <td>11</td> <td>HSYNC</td> <td>I</td> <td>HORIZONTAL SYNC INPUT HSYNCVSYNC AND PDEL CLOCK IS NECESSARY.</td> </tr> <tr> <td>40</td> <td>VCC</td> <td>P</td> <td>POWER SUPPLY FOR VCOM DRIVER CIRCUIT</td> </tr> </tbody> </table>	PIN NO	SYMBOL	LED	FUNCTION	5	VDD	P	POWER SUPPLY FOR VCOM DRIVER CIRCUIT	6	VDD	P	POWER SUPPLY FOR VCOM DRIVER CIRCUIT	9	ENB	I	DATA ENABLE INPUT	10	VSYNC	I	VERTICAL SYNC INPUT	11	HSYNC	I	HORIZONTAL SYNC INPUT	40	VCC	P	POWER SUPPLY FOR DIGITAL CIRCUIT	PIN NO	SYMBOL	LED	FUNCTION	5	VDD	P	POWER SUPPLY FOR DIGITAL CIRCUIT	6	VDD	P	POWER SUPPLY FOR DIGITAL CIRCUIT	9	ENB	I	DATA ENABLE INPUT DE MODE & SYNC MODE SETTING DE MODE : ONLY ENB AND PDEL CLOCK IS NECESSARY.	10	VSYNC	I	VERTICAL SYNC INPUT SYNC MODE : ENB SHOULD BE CONNECTED TO VSS.	11	HSYNC	I	HORIZONTAL SYNC INPUT HSYNCVSYNC AND PDEL CLOCK IS NECESSARY.	40	VCC	P	POWER SUPPLY FOR VCOM DRIVER CIRCUIT																								
PIN NO	SYMBOL	LED	FUNCTION																																																																															
5	VDD	P	POWER SUPPLY FOR VCOM DRIVER CIRCUIT																																																																															
6	VDD	P	POWER SUPPLY FOR VCOM DRIVER CIRCUIT																																																																															
9	ENB	I	DATA ENABLE INPUT																																																																															
10	VSYNC	I	VERTICAL SYNC INPUT																																																																															
11	HSYNC	I	HORIZONTAL SYNC INPUT																																																																															
40	VCC	P	POWER SUPPLY FOR DIGITAL CIRCUIT																																																																															
PIN NO	SYMBOL	LED	FUNCTION																																																																															
5	VDD	P	POWER SUPPLY FOR DIGITAL CIRCUIT																																																																															
6	VDD	P	POWER SUPPLY FOR DIGITAL CIRCUIT																																																																															
9	ENB	I	DATA ENABLE INPUT DE MODE & SYNC MODE SETTING DE MODE : ONLY ENB AND PDEL CLOCK IS NECESSARY.																																																																															
10	VSYNC	I	VERTICAL SYNC INPUT SYNC MODE : ENB SHOULD BE CONNECTED TO VSS.																																																																															
11	HSYNC	I	HORIZONTAL SYNC INPUT HSYNCVSYNC AND PDEL CLOCK IS NECESSARY.																																																																															
40	VCC	P	POWER SUPPLY FOR VCOM DRIVER CIRCUIT																																																																															
	13	<p>11.1 POWER SUPPLY FOR LCM</p>																																																																																
	14	<p>12.2.4 Inspection method (b)AQL : 0.65% →0.65 1.0% → 1.0</p>																																																																																
MAR.16, 2009	0-3	<p>10. INTERFACE SIGNAL → 10. INTERFACE SIGNALS</p>																																																																																
	7	<p>NOTE (3) : CONTRAST RATIO(CR) → CONTRAST RATIO(CR) NOTE (4) : DEFINITION OF RESPONSE TIME : TR AND TF THE FIGURE BELOW IS THE OUTPUT SIGNAL OF THE PHOTO DETECTOR. → NOTE (4) : DEFINITION OF RESPONSE TIME : TR AND TF THE FIGURE BELOW IS THE OUTPUT SIGNAL OF THE PHOTO DETECTOR.</p>																																																																																

MODEL NO.	VERSION	PAGE
ET057010DMU	5	0-3

RECORDS OF REVISION	DOC . FIRST ISSUE	OCT.30, 2007
---------------------	-------------------	--------------

DATE	REVISED PAGE NO.	SUMMARY
MAR.16, 2009	7	6.3 THE CALCULATING METHOD OF UNIFORMITY UNIFORMITY: $\left[1 - \frac{\text{MAXIMUM BRIGHTNESS} - \text{MINIMUM BRIGHTNESS}}{\text{AVERAGE BRIGHTNESS}} \right] \times 100\% \rightarrow$ UNIFORMITY: $\left[1 - \frac{\text{MAXIMUM BRIGHTNESS} - \text{MINIMUM BRIGHTNESS}}{\text{AVERAGE BRIGHTNESS}} \right] \times 100\%$
	8	7. OUTLINE DIMENSIONS MARK Δ : ADD PULL TAPE & MODIFY C/N TYPE
	15	12.3.1 VISUAL DEFECTS CLASSIFICATION MINOR DEFECT (1.DISPLAY ZONE) : LEVER COLOR SPREED \rightarrow LEVER COLOR SPREAD
AUG.12, 2014	8	7. OUTLINE DIMENSIONS MARK Δ : MODIFY C/N TYPE

CONFIDENTIAL
 Authorized for
 Emerging Display Technologies Corporation Only
 Do not distribute without authorization.

TABLE OF CONTENTS

NO.	ITEM	PAGE
1.	GENERAL SPECIFICATIONS -----	1
2.	MECHANICAL SPECIFICATIONS -----	1
3.	ABSOLUTE MAXIMUM RATINGS -----	2
4.	ELECTRICAL CHARACTERISTICS -----	3
5.	TIMING CHART -----	4 ,5
6.	OPTICAL CHARACTERISTICS -----	6 , 7
7.	OUTLINE DIMENSIONS -----	8
8.	BLOCK DIAGRAM -----	9
9.	DETAIL DRAWING OF DOT MATRIX -----	10
10.	INTERFACE SIGNALS -----	11 , 12
11.	POWER SUPPLY -----	13
12.	INSPECTION CRITERION -----	14 ~ 23

CONFIDENTIAL
Authorized for
Emerging Display Technologies Corporation Only.
Do not distribute without authorization.

1. GENERAL SPECIFICATIONS

1.1 APPLICATION NOTES FOR CONTROLLER/DRIVER

PLEASE REFER TO :

HIMAX HX8250

HIMAX HX8678

1.2 MATERIAL SAFETY DESCRIPTION

ASSEMBLIES SHALL COMPLY WITH EUROPEAN ROHS REQUIREMENTS, INCLUDING PROHIBITED MATERIALS/COMPONENTS CONTAINING LEAD, MERCURY, CADMIUM, HEXAVALENT CHROMIUM, POLYBROMINATED BIPHENYLS (PBB) AND POLYBROMINATED DIPHENYL ETHERS (PBDE)

2. MECHANICAL SPECIFICATIONS

(1) DIAGONALS	-----	5.7 inch
(2) NUMBER OF DOTS	-----	640W * (RGB) * 480H DOTS
(3) MODULE SIZE	-----	147.6W * 100.0H * 10.8D (MAX) mm (WITHOUT FPC)
(4) EFFECTIVE AREA	-----	117.2W * 88.4H mm
(5) ACTIVE AREA	-----	115.2W * 86.4H mm
(6) DOT SIZE	-----	0.06W * 0.18H mm
(7) PIXEL SIZE	-----	0.18W * 0.18H mm
(8) LCD TYPE	-----	TFT , TRANSMISSIVE
(9) COLOR	-----	16.7M
(10) VIEWING DIRECTION	-----	12 O'CLOCK
(11) BACK LIGHT	-----	LED , COLOR : WHITE
(12) INTERFACE MODE	-----	RGB 24BIT PARALLEL (DE/SYNC MODE)

3. ABSOLUTE MAXIMUM RATINGS

3.1 ELECTRICAL ABSOLUTE MAXIMUM RATINGS .

VSS=0V

PARAMETER	SYMBOL	MIN.	MAX.	UNIT	REMARK
POWER SUPPLY VOLTAGE	VCC	-0.3	7.0	V	
	VDD	-0.3	7.0	V	
INPUT VOLTAGE	V _{in}	-0.3	VCC+0.3	V	
LED BACKLIGHT DISSIPATION	PD	—	1.28	W	
LED BACKLIGHT CURRENT	IF	—	0.06	A	
LED BACKLIGHT REVERSE VOLTAGE	VR	—	45	V	

3.2 ENVIRONMENTAL ABSOLUTE MAXIMUM RATINGS .

I T E M	OPERATING		STORAGE		REMARK
	MIN.	MAX.	MIN.	MAX.	
AMBIENT TEMPERATURE	-20°C	70°C	-30°C	80°C	NOTE (1) , (2)
HUMIDITY	NOTE (3)		NOTE (3)		WITHOUT CONDENSATION
VIBRATION	—	3.92 m/s ² (0.4 G)	—	19.6 m/s ² (2.0 G)	10~55Hz X,Y,Z,EACH 2HRS
SHOCK	—	58.8 m/s ² (6 G)	—	980 m/s ² (100 G)	6 m SECONDS XYZ DIRECTIONS 3 TIME EACH
CORROSIVE GAS	NOT ACCEPTABLE		NOT ACCEPTABLE		

NOTE (1) : Ta AT -30°C : 48HR MAX .
80°C : 168HR MAX .

NOTE (2) : BACKGROUND COLOR CHANGES SLIGHTLY DEPENDING ON AMBIENT TEMPERATURE
THIS PHENOMENON IS REVERSIBLE.

NOTE (3) : Ta ≤ 60°C : 90%RH MAX (96HRS MAX).

Ta > 60°C : ABSOLUTE HUMIDITY MUST BE LOWER THAN THE HUMIDITY
OF 90%RH AT 60°C(96HRS MAX).

4. ELECTRICAL CHARACTERISTICS

Ta = 25 °C

PARAMETER	SYMBOL	CONDITION	MIN.	TYP.	MAX.	UNIT	REMARK
POWER SUPPLY VOLTAGE FOR VCOM	VCC	—	3	3.3	3.6	V	
POWER SUPPLY VOLTAGE FOR LCD	VDD	—	3	3.3	3.6	V	
POWER SUPPLY CURRENT FOR VCOM	ICC	VCC = 3.3V LED B/L = ON	—	510	600	mA	
POWER SUPPLY CURRENT FOR LCD	IDD	VDD = 3.3V	—	8	12	mA	
LOW LEVEL INPUT VOLTAGE	VIL	—	0	—	0.3*VCC	V	
HIGH LEVEL INPUT VOLTAGE	VIH	—	0.7*VCC	—	VCC	V	
OUTPUT LOW VOLTAGE	VOL	IOL = 400µA	0	—	0.2*VCC	V	
OUTPUT HIGH VOLTAGE	VOH	IOH = -400µA	0.8*VCC	—	VCC	V	
FRAME FREQUENCY	fFRAME	—	50	60	72	Hz	
LED BACKLIGHT FORWARD VOLTAGE	V _F	I _F =40mA	28	30	32	V	NOTE(1)
LED LIFE TIME	—	—	30000	40000	—	hr	

NOTE (1) : INTERNAL CIRCUIT DIAGRAM OF BACKLIGHT

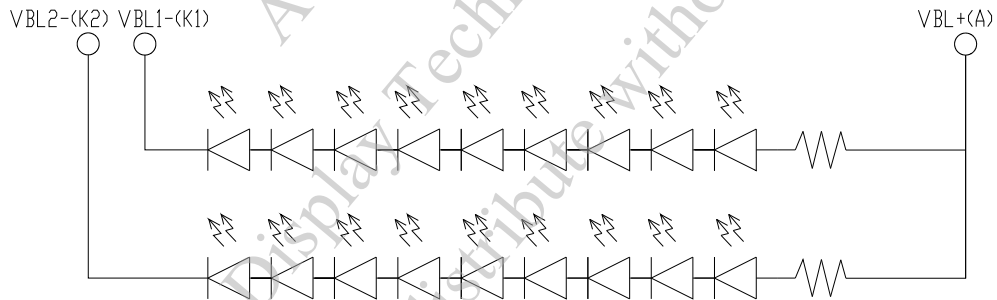

NOTE (2) : AMBIENT TEMP. VS. ALLOWABLE FORWARD CURRENT. (PER LED)

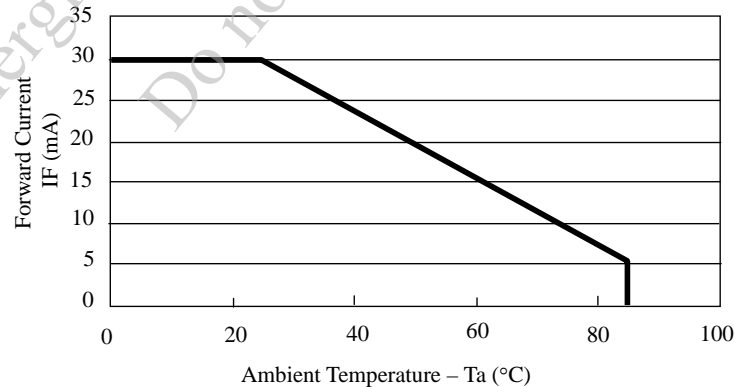

5. TIMING CHART

5.1 DIGITAL PARALLEL RGB INTERFACE (SYNC MODE)

ITEM	SYMBOL	MIN.	TYP.	MAX.	UNIT
DCLK FREQUENCY	F_{CPH}	22.66	25.175	27.69	MHz
DCLK PERIOD	T_{CPH}	36.11	39.7	44.13	ns
DCLK PULSE DUTY	T_{CWH}	40	50	60	%
HSYNC PERIOD	T_H	750	800	850	T_{CPH}
HSYNC PULSE WIDTH	T_{WH}	5	30	—	T_{CPH}
HSYNC FIRST HORIZONTAL DATA TIME	T_{HS}	112	144	175	T_{CPH}
HORIZONTAL ACTIVE DATA AREA	T_{HA}	—	640	—	T_{CPH}
VSYNC PULSE WIDTH	T_{WV}	1	3	5	T_H
FIRST LINE DATA INPUT TIME	T_{STV}	—	35	—	T_H
VSYNC PERIOD	T_V	515	525	535	T_H

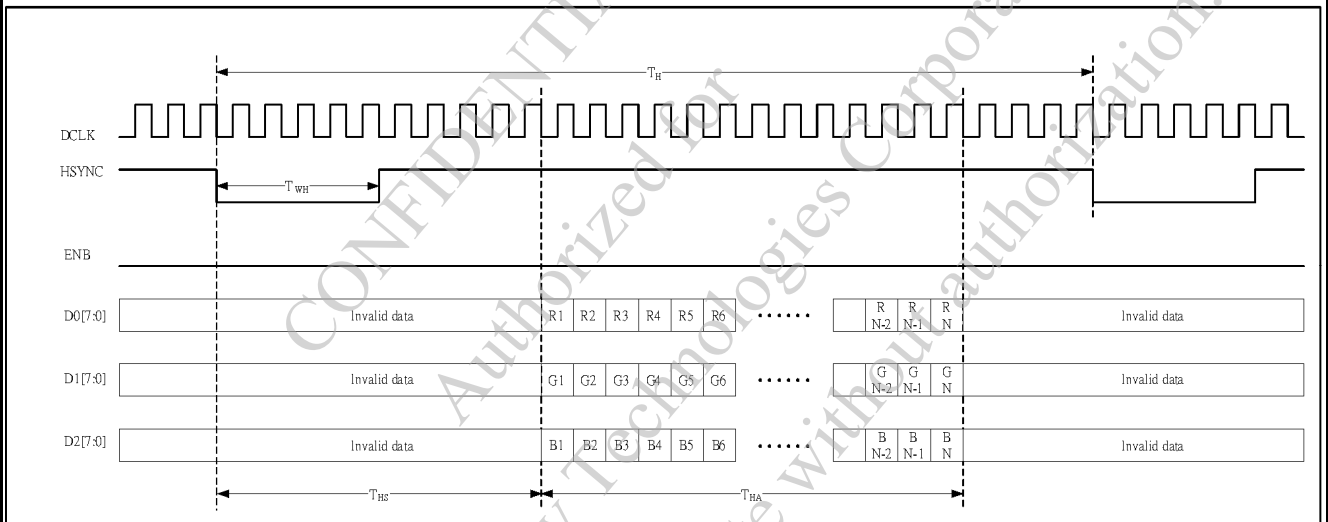

HORIZONTAL TIMING

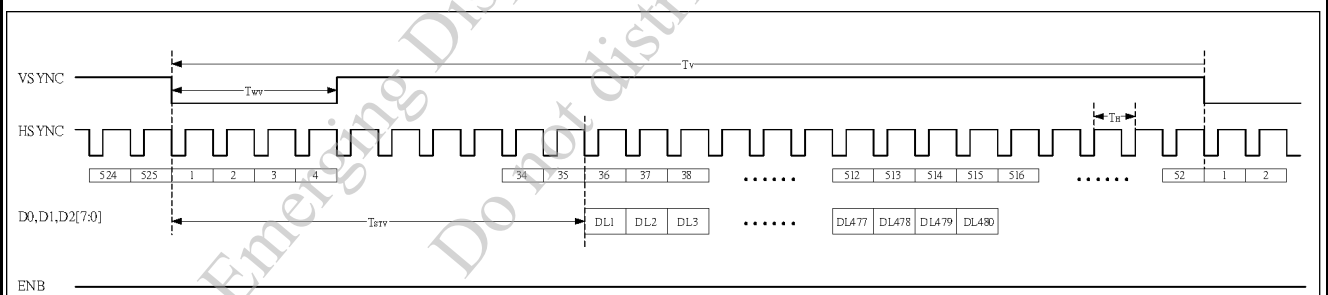

VERTICAL TIMING

5.2 DIGITAL PARALLEL RGB INTERFACE (DE MODE)

ITEM	SYMBOL	MIN.	TYP.	MAX.	UNIT
DCLK FREQUENCY	F_{CPH}	22.66	25.175	27.69	MHz
DCLK PERIOD	T_{CPH}	36.11	39.7	44.13	ns
DCLK PULSE DUTY	T_{CWH}	40	50	60	%
ENB PERIOD	T_{DEN}	750	800	850	T_{CPH}
ENB PULSE WIDTH	T_{EP}	—	640	—	T_{CPH}
ENB FRAME ACTIVE TIME	T_{DEA}	—	480	—	T_H
ENB FRAME BLANKING TIME	T_{DEB}	10	45	110	T_H

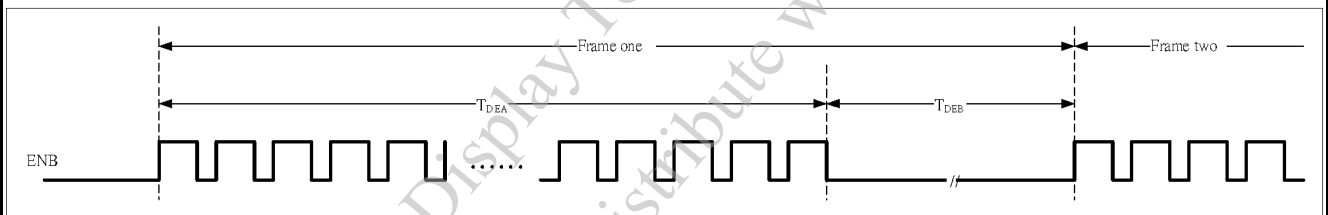
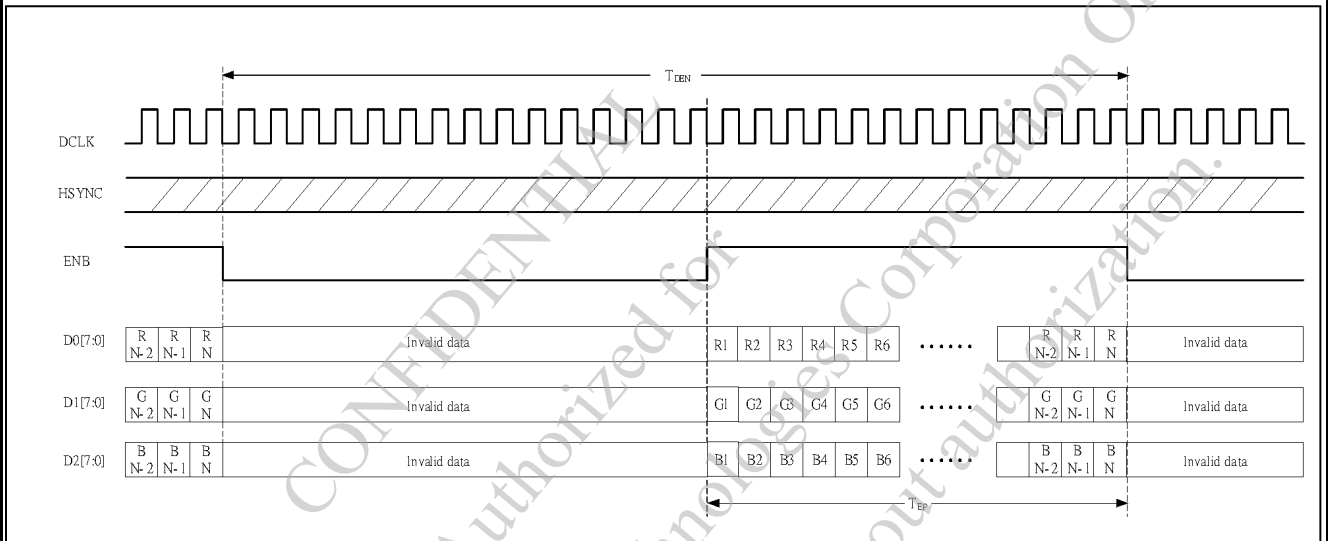

CONFIDENTIAL
 Authorized for Emerging Display Technologies Corporation Only
 Do not distribute without authorization.

6. OPTICAL CHARACTERISTICS (NOTE1)
6.1 OPTICAL CHARACTERISTICS

Ta = 25 ± 2 °C

I T E M		SYMBOL	CONDITION	MIN.	TYP.	MAX.	UNIT	REMARK	
VIEWING ANGLE		θ_{y+}	CR ≥ 10	$\theta_x=0^\circ$	50	55	—	deg.	(2)
		θ_{y-}			47	52	—		
		θ_{x+}	$\theta_y=0^\circ$	60	65	—	(3)		
		θ_{x-}		60	65	—			
CONTRAST RATIO		CR	$\theta_x=0^\circ, \theta_y=0^\circ$	300	350	—	—	(3)	
RESPONSE TIME		T _R (rise)	$\theta_x=0^\circ, \theta_y=0^\circ$	—	15	30	msec	(4)	
		T _F (fall)		—	35	50			
THE BRIGHTNESS OF MODULE		B	$\theta_x=0^\circ, \theta_y=0^\circ$ IF = 40mA	400	450	—	cd/m ²	(5)	
COLOR OF CIE COORDINATE	WHITE	W _x	$\theta_x=0^\circ, \theta_y=0^\circ$ IF = 40mA NTSC : 50 %	0.26	0.31	0.36	—	(6)	
		W _y		0.30	0.35	0.40			
	RED	R _x		0.56	0.61	0.66	—		
		R _y		0.31	0.36	0.41			
	GREEN	G _x		0.28	0.33	0.38	—		
		G _y		0.51	0.56	0.61			
	BLUE	B _x		0.09	0.14	0.19	—		
		B _y		0.07	0.12	0.17			
THE UNIFORMITY OF MODULE		—	IF=40mA	75	80	—	%	—	

NOTE (1) : TEST EQUIPMENT SETUP :

AFTER STABILIZING AND LEAVING THE PANEL ALONE AT A GIVEN TEMPERATURE FOR 30 MINUTES, THE MEASUREMENT SHOULD BE EXECUTED. MEASUREMENT SHOULD BE EXECUTED IN A STABLE, WINDLESS, AND DARK ROOM. OPTICAL SPECIFICATIONS ARE MEASURED BY TOPCON BM-7 (FAST) WITH A VIEWING ANGLE OF 1° AT A DISTANCE OF 50cm AND NORMAL DIRECTION.

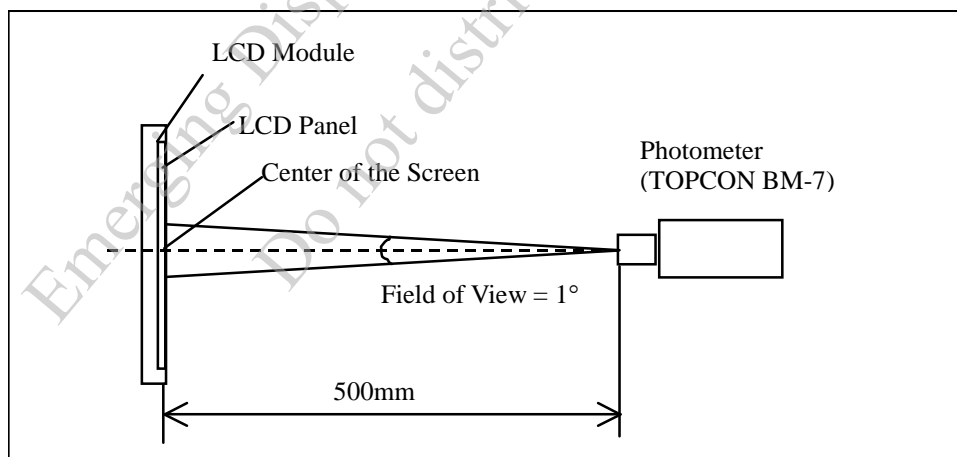

NOTE (2) : DEFINITION OF VIEWING ANGLE :

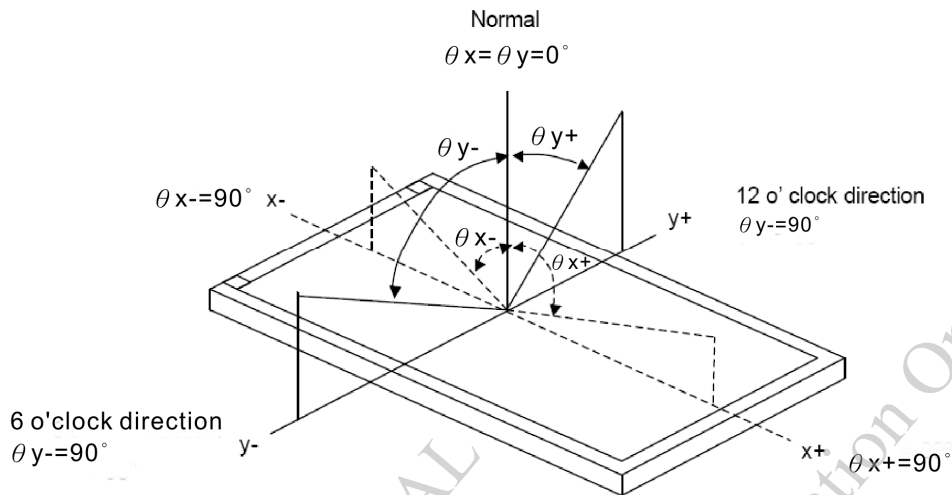

NOTE (3) : DEFINITION OF CONTRAST RATIO :

$$\text{CONTRAST RATIO (CR)} = \frac{\text{BRIGHTNESS MEASURED WHEN LCD IS AT "WHITE STATE"}}{\text{BRIGHTNESS MEASURED WHEN LCD IS AT "BLACK STATE"}}$$

NOTE (4) : DEFINITION OF RESPONSE TIME : TR AND TF

THE FIGURE BELOW IS THE OUTPUT SIGNAL OF THE PHOTO DETECTOR.

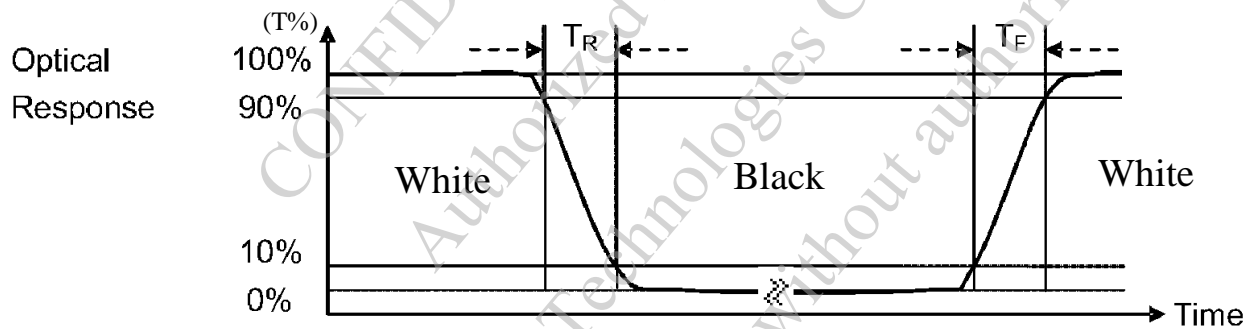

NOTE (5) : BRIGHTNESS MEASURED WHEN LCD IS AT "WHITE STATE"

NOTE (6) : THE 100% TRANSMISSION IS DEFINED AS THE TRANSMISSION OF LCD PANEL WHEN ALL THE INPUT TERMINALS OF MODULE ARE ELECTRICALLY OPENED.

6.2 THE TEST METHOD OF BRIGHTNESS AND UNIFORMITY

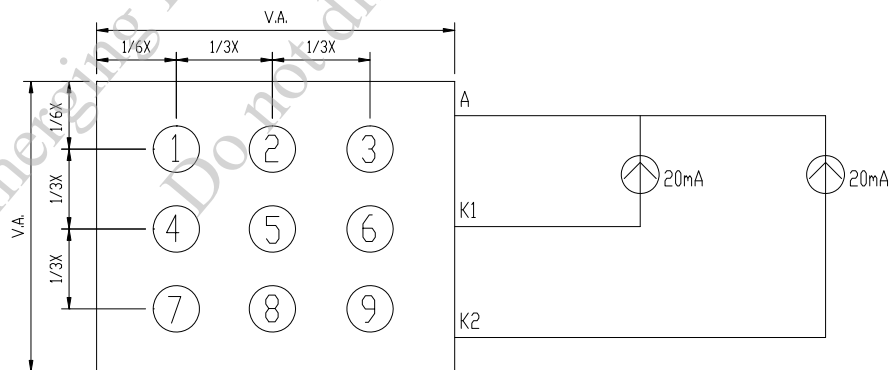

6.3 THE CALCULATING METHOD OF UNIFORMITY

$$\text{UNIFORMITY} = \left[1 - \frac{\text{MAXIMUM BRIGHTNESS} - \text{MINIMUM BRIGHTNESS}}{\text{AVERAGE BRIGHTNESS}} \right] \times 100\%$$

7. OUTLINE DIMENSIONS

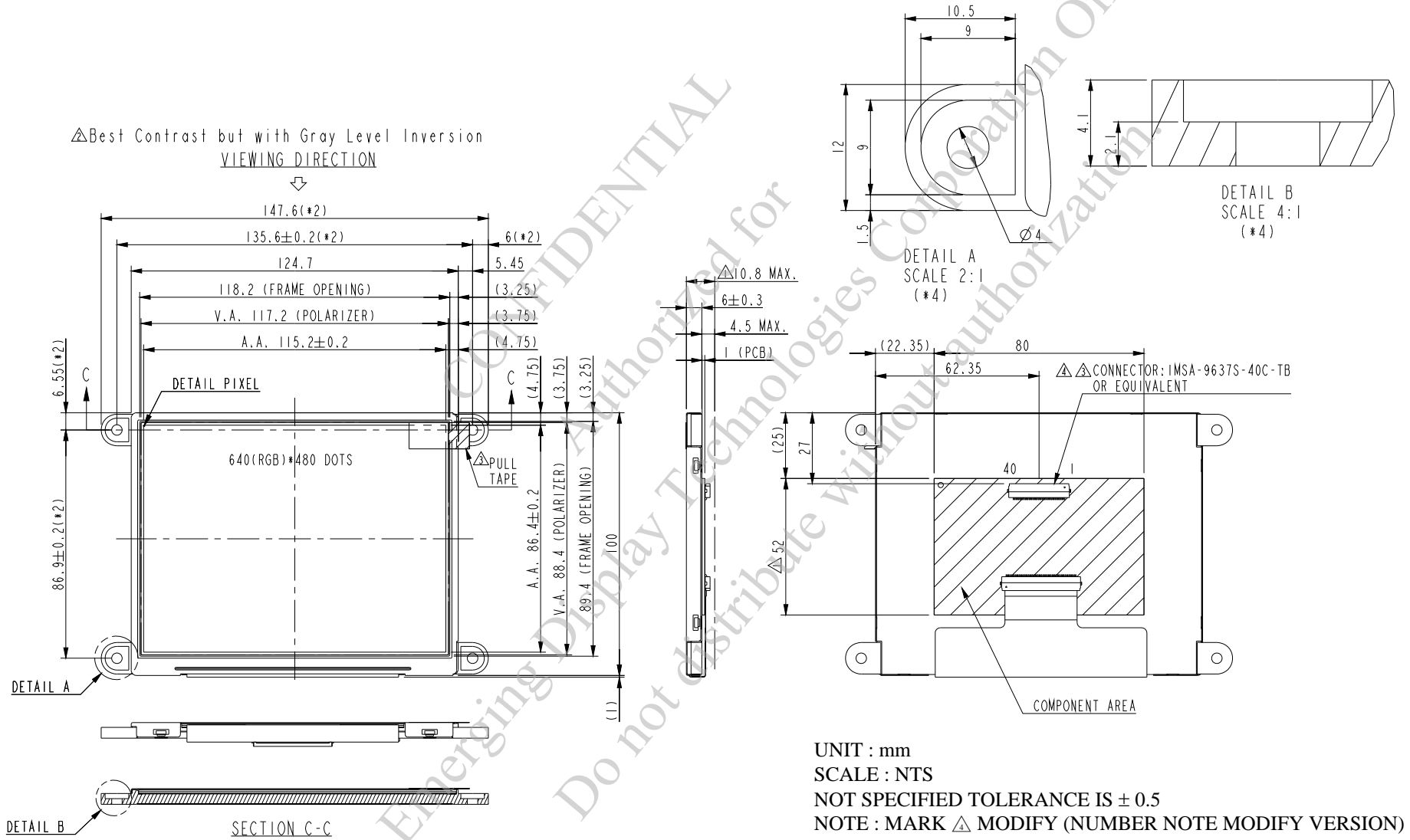

8. BLOCK DIAGRAM

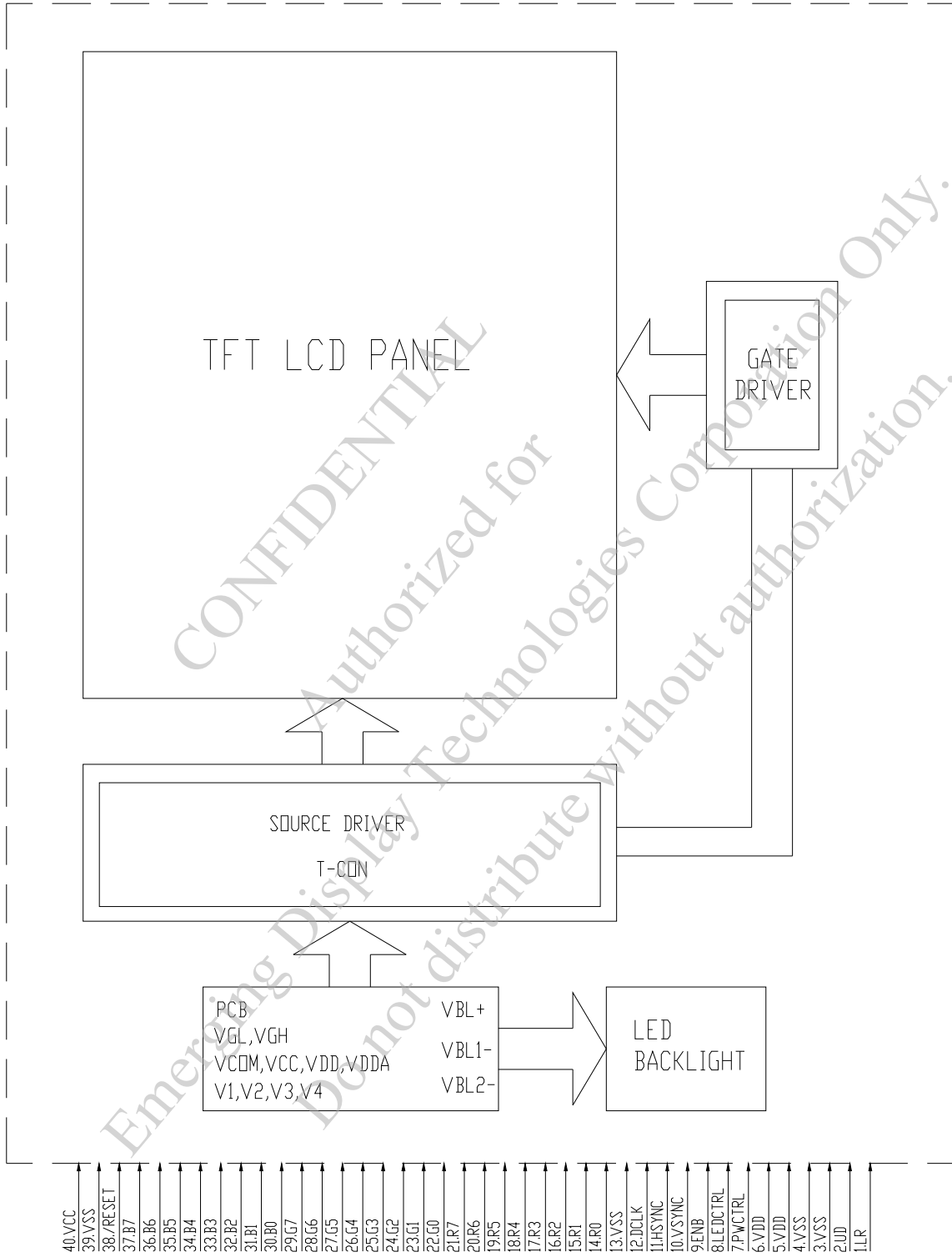

9. DETAIL DRAWING OF DOT MATRIX

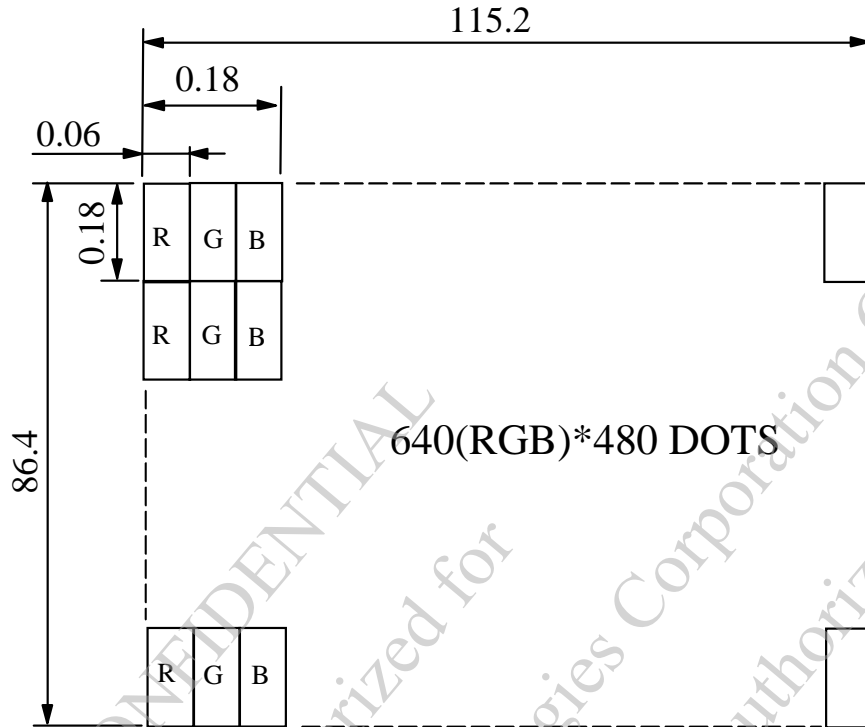

UNIT : mm
SCALE : NTS
NOT SPECIFIED TOLERANCE IS ± 0.1
DOTS MATRIX TOLERANCE IS ± 0.01

CONFIDENTIAL
Authorized for Emerging Display Technologies Corporation Only.
Do not distribute without authorization.

10. INTERFACE SIGNALS

PIN NO	SYMBOL	I/O	FUNCTION										
1	LR	I	LR=H:STH→S01→ ---- → S0960 → STHO LR=L:STH→S960→ ---- → S01 → STHO										
2	UD	I	UP/DOWN SCAN SETTING UD=H, REVERSE SCAN UD=L, NORMAL SCAN										
3, 4	VSS	P	GROUND										
5	VDD	P	POWER SUPPLY FOR DIGITAL CIRCUIT										
6	VDD	P	POWER SUPPLY FOR DIGITAL CIRCUIT										
7	PWCTRL	I	<table border="1"> <thead> <tr> <th></th> <th>PWCTRL</th> <th>REMARK</th> </tr> </thead> <tbody> <tr> <td>LOGIC LEVEL H = 3.3V L = 0V</td> <td>H</td> <td>POWER ON</td> </tr> <tr> <td></td> <td>L</td> <td>SHUTDOWN</td> </tr> </tbody> </table>			PWCTRL	REMARK	LOGIC LEVEL H = 3.3V L = 0V	H	POWER ON		L	SHUTDOWN
				PWCTRL	REMARK								
LOGIC LEVEL H = 3.3V L = 0V	H	POWER ON											
	L	SHUTDOWN											
8	LEDCTRL	I	BRIGHTNESS CONTROL FOR LED B/L										
9	ENB	I	DATA ENABLE INPUT	DE MODE & SYNC MODE SETTING DE MODE : ONLY ENB AND PIXEL CLOCK IS NECESSARY. SYNC MODE : ENB SHOULD BE CONNECTED TO VSS.									
10	VSYNC	I	VERTICAL SYNC INPUT										
11	HSYNC	I	HORIZONTAL SYNC INPUT	HSYNC/VSYNC AND PIXEL CLOCK IS NECESSARY.									
12	DCLK	I	DOT DATA COLOCK										
13	VSS	P	GROUND										
14	R0	I	RED DATA BIT 0										
15	R1	I	RED DATA BIT 1										
16	R2	I	RED DATA BIT 2										
17	R3	I	RED DATA BIT 3										
18	R4	I	RED DATA BIT 4										
19	R5	I	RED DATA BIT 5										
20	R6	I	RED DATA BIT 6										
21	R7	I	RED DATA BIT 7										
22	G0	I	GREEN DATA BIT 0										
23	G1	I	GREEN DATA BIT 1										
24	G2	I	GREEN DATA BIT 2										
25	G3	I	GREEN DATA BIT 3										
26	G4	I	GREEN DATA BIT 4										
27	G5	I	GREEN DATA BIT 5										
28	G6	I	GREEN DATA BIT 6										
29	G7	I	GREEN DATA BIT 7										
30	B0	I	BLUE DATA BIT 0										
31	B1	I	BLUE DATA BIT 1										

PIN NO	SYMBOL	I/O	FUNCTION
32	B2	I	BLUE DATA BIT 2
33	B3	I	BLUE DATA BIT 3
34	B4	I	BLUE DATA BIT 4
35	B5	I	BLUE DATA BIT 5
36	B6	I	BLUE DATA BIT 6
37	B7	I	BLUE DATA BIT 7
38	/RESET	I	HARDWARE RESET
39	VSS	P	GROUND
40	VCC	P	POWER SUPPLY FOR VCOM DRIVER CIRCUIT

CONFIDENTIAL
 Authorized for
 Emerging Display Technologies Corporation Only.
 Do not distribute without authorization.

1 1 . POWER SUPPLY
1 1 .1 POWER SUPPLY FOR LCM

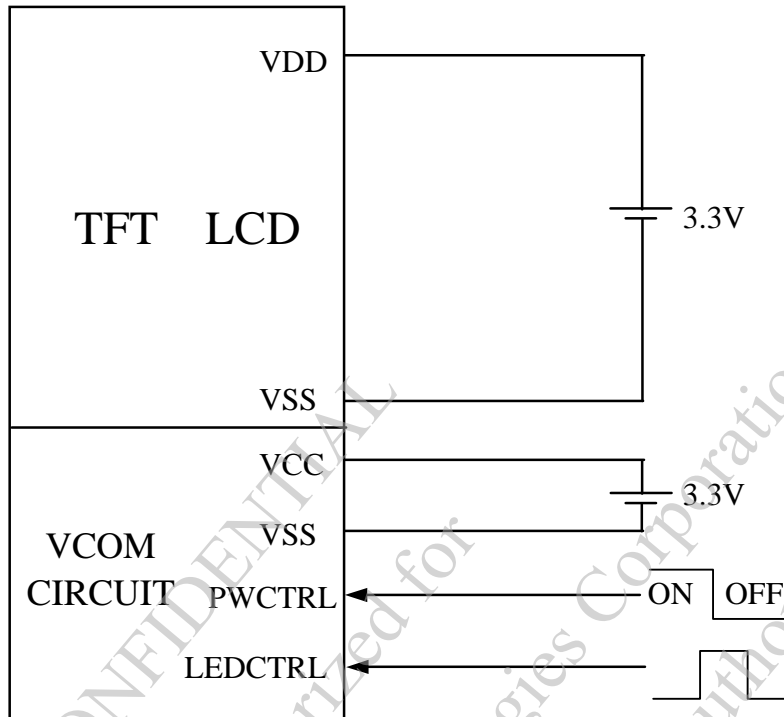

1 1 .2 THE BRIGHTNESS CONTROLLED BY PWM SIGNAL OF LEDCTRL
(1) IF THE DUTY IS BIGGER, THE BRIGHTNESS WILL BE LOWER.

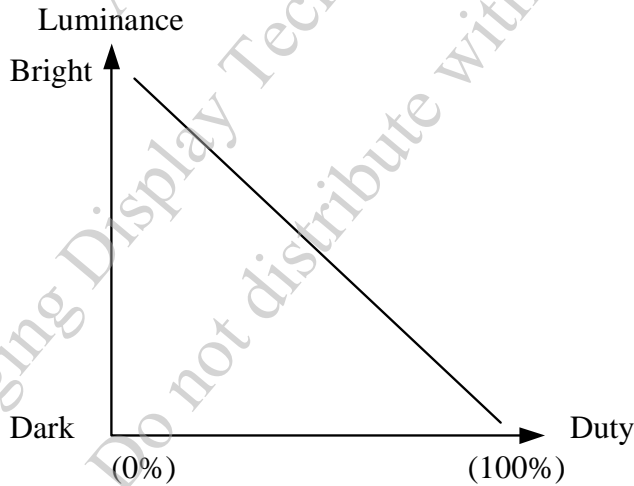

(2) SIGNAL OPERATION FREQUENCY IS 1K ~ 2KHz.

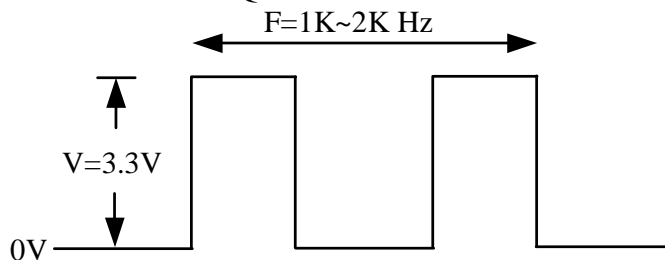

12. INSPECTION CRITERION

12.1 APPLICATION

This inspection standard is to be applied to the LCD module delivered from EMERGING DISPLAY TECHNOLOGIES CORP.(E.D.T) to customers

12.2 INSPECTION CONDITIONS

12.2.1 (1) Observation Distance : 35cm±5cm

(2) View Angle :

Non-operation Condition : ±5°(perpendicular to LCD panel surface)

Operation Condition : ±45° (perpendicular to LCD panel surface)

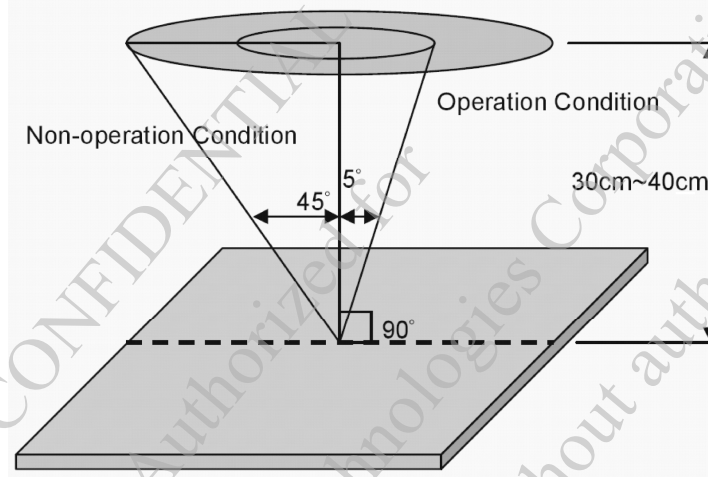

12.2.2 Environment Conditions :

Ambient Temperature		20°C~25°C
Ambient Humidity		65±20%RH
Ambient Illumination	Cosmetic Inspection	More than 600Lux
	Functional Inspection	300~500 Lux

12.2.3 Inspection lot

Quantity per delivery lot for each model

12.2.4 Inspection method

A sampling inspection shall be made according to the following provisions to judge The acceptability

(a)Applicable standard : MIL-STD-105E

Normal inspection, single sampling

Level II

(b)AQL : Major defect : AQL 0.65

Minor defect : AQL 1.0

12.3 INSPECTION STANDARDS

12.3.1 VISUAL DEFECTS CLASSIFICATION

TYPE OF DEFECT	INSPECTION ITEM	DEFECT FEATURE	AQL
MAJOR DEFECT	1.DISPLAY ON	<ul style="list-style-type: none"> • DEFECT TO MISS SPECIFIED DISPLAY FUNCTION, FOR ALL AND SPECIFIED DOTS EX: DISCONNECTION, SHORT CIRCUIT ETC 	0.65
	2.BACKLIGHT	<ul style="list-style-type: none"> • NO LIGHT • FLICKERING AND OTHER ABNORMAL ILLUMINATION 	
	3.DIMENSIONS	<ul style="list-style-type: none"> • SUBJECT TO INDIVIDUAL ACCEPTANCE SPECIFICATIONS 	
MINOR DEFECT	1.DISPLAY ZONE	<ul style="list-style-type: none"> • BLACK/WHITE SPOT • BUBBLES ON POLARIZER • NEWTON RING • BLACK/WHITE LINE • SCRATCH • CONTAMINATION • LEVER COLOR SPREAD 	1.0
	2.BEZEL ZONE	<ul style="list-style-type: none"> • STAINS • SCRATCHES • FOREIGN MATTER 	
	3.SOLDERING	<ul style="list-style-type: none"> • INSUFFICIENT SOLDER • SOLDERED IN INCORRECT POSITION • CONVEX SOLDERING SPOT • SOLDER BALLS • SOLDER SCRAPS 	
	4.DISPLAY ON (ALL ON)	<ul style="list-style-type: none"> • LIGHT LINE 	

12.3.2 MODULE DEFECTS CALSSIFICATION

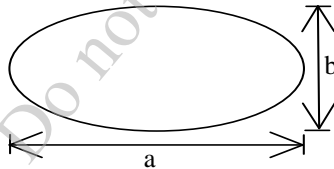
NO.	ITEM	CRITERIA												
1.	DISPLAY ON INSPECTION	(1)INCORRECT PATTERN (2)MISSING SEGMENT (3)DIM SEGMENT (4)OPERATING VOLTAGE BEYOND SPEC												
2.	OVERALL DIMENSIONS	(1)OVERALL DIMENSION BEYOND SPEC												
3.	DOT DEFECT	(1) INSPECTION PATTERN: FULL WHITE, FULL BLACK, RED, GREEN AND BLUE SCREENS. (2) <table border="1" style="margin-left: 20px;"> <thead> <tr> <th>ITEMS</th> <th>ACCEPTABLE COUNT</th> </tr> </thead> <tbody> <tr> <td>BRIGHT DOT</td> <td>$N \leq 2$</td> </tr> <tr> <td>DARK DOT</td> <td>$N \leq 3$</td> </tr> <tr> <td>TOAL BRIGHT AND DARK DOTS</td> <td>$N \leq 4$</td> </tr> </tbody> </table> <p>NOTE :</p> <p>1. THE DEFINITION OF DOT : THE SIZE OF A DEFECTIVE DOT OVER 1/2 OF WHOLE DOT IS REGARDED AS ONE DEFECTIVE DOT.</p> <p>2. BRIGHT DOT : DOTS APPEAR BRIGHT AND UNCHANGED IN SIZE IN WHICH LCD PANEL IS DISPLAYING UNDER BLACK PATTERN.</p> <p>3. DARK DOT : DOTS APPEAR DARK AND UNCHANGED IN SIZE IN WHICH LCD PANEL IS DISPLAYING UNDER PURE RED, GREEN, BLUE PICTURE.</p>	ITEMS	ACCEPTABLE COUNT	BRIGHT DOT	$N \leq 2$	DARK DOT	$N \leq 3$	TOAL BRIGHT AND DARK DOTS	$N \leq 4$				
ITEMS	ACCEPTABLE COUNT													
BRIGHT DOT	$N \leq 2$													
DARK DOT	$N \leq 3$													
TOAL BRIGHT AND DARK DOTS	$N \leq 4$													
4.	FOREIGN BLACK/WHITE/ BRIGHT LINE/ SCRATCH OF VIEWING AREA	<table border="1" style="margin-left: 20px;"> <thead> <tr> <th>LENGTH : L</th> <th>WIDTH : W</th> <th>PERMISSIBLE NO.</th> </tr> </thead> <tbody> <tr> <td>$L \leq 0.3$</td> <td>$W \leq 0.05$</td> <td>IGNORE</td> </tr> <tr> <td>$0.3 < L \leq 2.5$</td> <td>$0.05 < W \leq 0.1$</td> <td>4</td> </tr> <tr> <td>$2.5 < L$</td> <td>$0.1 < W$</td> <td>NONE</td> </tr> </tbody> </table> <p>WIDTH : W mm, LENGH : L mm</p>	LENGTH : L	WIDTH : W	PERMISSIBLE NO.	$L \leq 0.3$	$W \leq 0.05$	IGNORE	$0.3 < L \leq 2.5$	$0.05 < W \leq 0.1$	4	$2.5 < L$	$0.1 < W$	NONE
LENGTH : L	WIDTH : W	PERMISSIBLE NO.												
$L \leq 0.3$	$W \leq 0.05$	IGNORE												
$0.3 < L \leq 2.5$	$0.05 < W \leq 0.1$	4												
$2.5 < L$	$0.1 < W$	NONE												
5.	FOREIGN MATTER \ BLACK SPOTS \ WHITE SPOTS \ DENT (INCLUDING LIGHT LEAKAGE DUE TO POLARIZING PLATES PINHOLES, ETC.)	<table border="1" style="margin-left: 20px;"> <thead> <tr> <th>AVERAGE DIAMETER (mm): D</th> <th>NUMBER OF PIECES PERMITTED</th> </tr> </thead> <tbody> <tr> <td>$D \leq 0.15$</td> <td>IGNORE</td> </tr> <tr> <td>$0.15 < D \leq 0.5$</td> <td>4</td> </tr> <tr> <td>$0.5 < D$</td> <td>NONE</td> </tr> </tbody> </table> <p>NOTE : DIAMETER $D=(a+b)/2$</p> 	AVERAGE DIAMETER (mm): D	NUMBER OF PIECES PERMITTED	$D \leq 0.15$	IGNORE	$0.15 < D \leq 0.5$	4	$0.5 < D$	NONE				
AVERAGE DIAMETER (mm): D	NUMBER OF PIECES PERMITTED													
$D \leq 0.15$	IGNORE													
$0.15 < D \leq 0.5$	4													
$0.5 < D$	NONE													

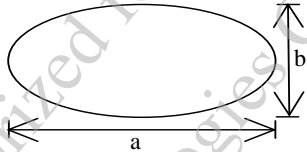
NO.	ITEM	CRITERIA		
			AVERAGE DIAMETER (mm) : D	NUMBER OF PIECES PERMITTED
6.	BUBBLES OF POLARIZER /DIRT/CF FAIL /SURFACE STAINS	BUBBLE ON THE POLARIZER	$D \leq 0.25$	IGNORE
			$0.25 < D \leq 0.5$	$N \leq 5$
			$0.5 < D$	NOTE
		SURFACE STATUS	$D < 0.1 \text{ mm}$	IGNORE
			$0.1 < D \leq 0.3\text{mm}$	$N \leq 3$
		CF FAIL / SPOT	$D < 0.1 \text{ mm}$	IGNORE
$0.1 < D \leq 0.3\text{mm}$	$N \leq 3$			
		<p>NOTE : (1)POLARIZER BUBBLE IS DEFINED AS THE BUBBLE APPEARS ON ACTIVE DISPLAY AREA. THE DEFECT OF POLARIZER BUBBLE SHALL BE IGNORED IF THE POLARIZER BUBBLE APPEARS ON THE OUTSIDE OF ACTIVE DISPLAY AREA.</p> <p>(2)THE EXTRANEIOUS SUBSTANCE IS DEFINED AS IT CAN BE OBSERVED WHEN THE MODULE IS POWER ON.</p> <p>(3)THE DEFINITION OF AVERAGE DIAMETER, D IS DEFINED AS FOLLOWING.</p> <p>AVERAGE DIAMETER (D)=(a+b)/2</p> 		
7.	LINE DEFECT ON DISPLAY	OBVIOUS VERTICAL OR HORIZONTAL LINE DEFECT IS NOT ALLOW		
8.	MURA ON DISPLAY	IT'S OK IF MURA IS SLIGHT VISIBLE THROUG 6% ND FILTER		
9.	UNEVEN COLOR SPREAD, COLORATION	(1)TO BE DETERMINED BASED UPON THE STANDARD SAMPLE.		
10.	BEZEL APPEARANCE	(1)BEZEL MAY NOT HAVE RUST, BE DEFORMED OR HAVE FINGER PRINTS STAINS OF OTHER CONTAMINATION. (2)BEZEL MUST COMPLY WITH JOB SPECIFICATIONS.		
11	PCB	<p>(1)THERE MAY NOT BE MORE THAN 2mm OF SEALANT OUTSIDE THE SEAL AREA ON THE PCB, AND THERE SHOULD BE NO MORE THAN THREE PLACES.</p> <p>(2)NO OXIDATION OR CONTAMINATION PCB TERMINALS.</p> <p>(3)PARTS ON PCB MUST BE THE SAME AS ON THE PRODUCTION CHARACTERISTIC CHART. THERE SHOULD BE NO WRONG PARTS, MISSING PARTS OR EXCESS PARTS.</p> <p>(4)THE JUMPER ON THE PCB SHOULD CONFORM TO THE PRODUCT CHARACTERISTIC CHART.</p> <p>(5)IF SOLDER GETS ON BEZEL TAB PADS, LED PAD, ZEBRA PAD OR SCREW HOLD PAD; MAKE SURE IT IS SMOOTHED DOWN.</p>		

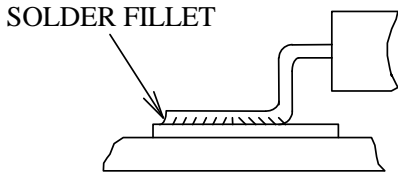
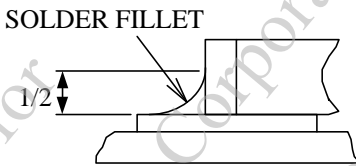
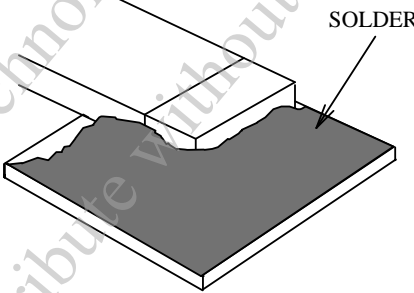
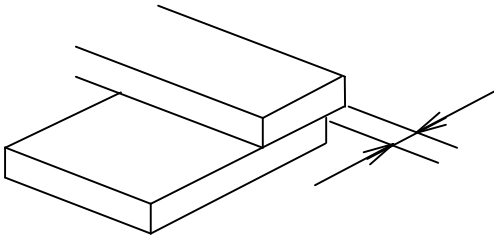
NO.	ITEM	CRITERIA
12.	SOLDERING	<p>(1) NO SOLDERING FOUND ON THE SPECIFIED PLACE</p> <p>(2) INSUFFICIENT SOLDER</p> <p>(a) LSI, IC A POOR WETTING OF SOLDER IS BETWEEN LOWER BEND OR "HEEL" OF LEAD AND PAD</p>  <p>(b) CHIP COMPONENT • SOLDER IS LESS THAN 50% OF SIDES AND FRONT FACE WETTING</p>  <p>• SOLDER WETS 3 SIDES OF TERMINAL, BUT LESS THAN 25% OF SIDES AND FRONT SURFACE AREA ARE COVERED</p>  <p>(3) PARTS ALIGNMENT</p> <p>(a) LSI, IC LEAD WIDTH IS MORE THAN 50% BEYOND PAD OUTLINE</p> 

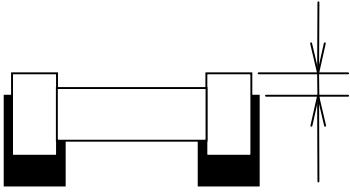
NO.	ITEM	CRITERIA
12.	SOLDERING	<p>(b)CHIP COMPONENT COMPONENT IS OFF CENTER, AND MORE THAN 50% OF THE LEADS IS OFF THE PAD OUTLINE</p>  <p>(4)NO UNMELTED SOLDER PASTE MAY BE PRESENT ON THE PCB. (5)NO COLD SOLDER JOINTS, MISSING SOLDER CONNECTIONS, OXIDATION OR ICICLE. (6)NO RESIDUE OR SOLDER BALLS ON PCB. (7)NO SHORT CIRCUITS IN COMPONENTS ON PCB.</p>
13.	BACKLIGHT	<p>(1)NO LIGHT (2)FLICKERING AND OTHER ABNORMAL ILLUMINATION (3)SPOTS OR SCRATCHES THAT APPEAR WHEN LIT MUST BE JUDGED USING LCD SPOT, LINES AND CONTAMINATION STANDARDS. (4)BACKLIGHT DOESN'T LIGHT OR COLOR IS WRONG.</p>
14.	GENERAL APPEARANCE	<p>(1)NO OXIDATION, CONTAMINATION, CURVES OR, BENDS ON INTERFACE PIN (OLB) OF TCP. (2)NO CRACKS ON INTERFACE PIN (OLB) OF TCP. (3)NO CONTAMINATION, SOLDER RESIDUE OR SOLDER BALLS ON PRODUCT. (4)THE IC ON THE TCP MAY NOT BE DAMAGED, CIRCUITS. (5)THE UPPERMOST EDGE OF THE PROTECTIVE STRIP ON THE INTERFACE PIN MUST BE PRESENT OR LOOK AS IF IT CAUSE THE INTERFACE PIN TO SEVER. (6)THE RESIDUAL ROSIN OR TIN OIL OF SOLDERING (COMPONENT OR CHIP COMPONENT) IS NOT BURNED INTO BROWN OR BLACK COLOR. (7)SEALANT ON TOP OF THE ITO CIRCUIT HAS NOT HARDENED. (8)PIN TYPE MUST MATCH TYPE IN SPECIFICATION SHEET. (9)LCD PIN LOOSE OR MISSING PINS. (10)PRODUCT PACKAGING MUST THE SAME AS SPECIFIED ON PACKAGING SPECIFICATION SHEET. (11)PRODUCT DIMENSION AND STRUCTURE MUST CONFORM TO PRODUCT SPECIFICATION SHEET. (12)THE APPEARANCE OF HEAT SEAL SHOULD NOT ADMIT ANY DIRT AND BREAK.</p>

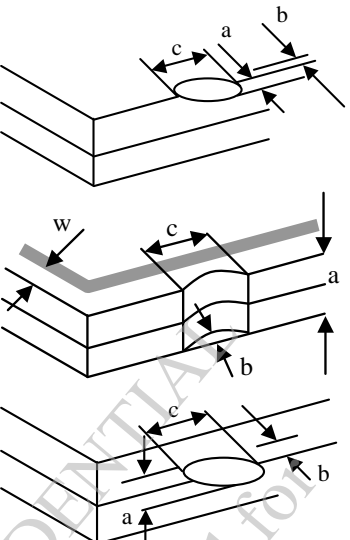
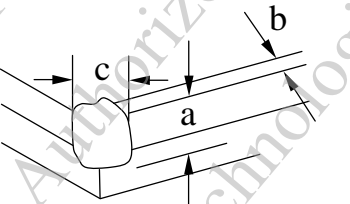
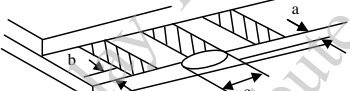
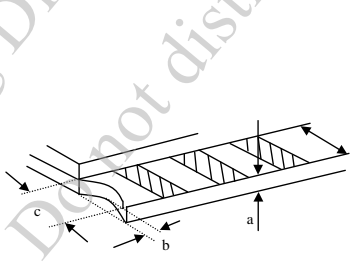
NO.	ITEM	CRITERIA										
15.	CRACKED GLASS	<p>THE LCD WITH EXTENSIVE CRACK IS NOT ACCEPTABLE</p>										
		<p>GENERAL GLASS CHIP :</p> 	<table border="1" data-bbox="935 416 1458 499"> <thead> <tr> <th>a</th> <th>b</th> <th>c</th> </tr> </thead> <tbody> <tr> <td>$\leq t/2$</td> <td>< VIEWING AREA</td> <td>$\leq 1/8X$</td> </tr> <tr> <td>$t/2 > , \leq 2t$</td> <td>$\leq W/2$</td> <td>$\leq 1/8X$</td> </tr> </tbody> </table> <p>*W=DISTANCE BETWEEN SEALANT AREA AND LCD PANEL EDGE X = LCD SIDE LENGTH t = GLASS THICKNESS</p>	a	b	c	$\leq t/2$	< VIEWING AREA	$\leq 1/8X$	$t/2 > , \leq 2t$	$\leq W/2$	$\leq 1/8X$
		a	b	c								
		$\leq t/2$	< VIEWING AREA	$\leq 1/8X$								
		$t/2 > , \leq 2t$	$\leq W/2$	$\leq 1/8X$								
<p>CORNER PART :</p> 	<table border="1" data-bbox="935 1005 1458 1088"> <thead> <tr> <th>a</th> <th>b</th> <th>c</th> </tr> </thead> <tbody> <tr> <td>$\leq t/2$</td> <td>< VIEWING AREA</td> <td>$\leq 1/8X$</td> </tr> <tr> <td>$> t/2 , \leq 2t$</td> <td>$\leq W/2$</td> <td>$\leq 1/8X$</td> </tr> </tbody> </table> <p>*W=DISTANCE BETWEEN SEALANT AREA AND LCD PANEL EDGE X = LCD SIDE LENGTH t = GLASS THICKNESS</p>	a	b	c	$\leq t/2$	< VIEWING AREA	$\leq 1/8X$	$> t/2 , \leq 2t$	$\leq W/2$	$\leq 1/8X$		
a	b	c										
$\leq t/2$	< VIEWING AREA	$\leq 1/8X$										
$> t/2 , \leq 2t$	$\leq W/2$	$\leq 1/8X$										
<p>CHIP ON ELECTRODE PAD</p> 	<table border="1" data-bbox="935 1279 1458 1339"> <thead> <tr> <th>a</th> <th>b</th> <th>c</th> </tr> </thead> <tbody> <tr> <td>$\leq t$</td> <td>$\leq 0.5\text{mm}$</td> <td>$\leq 1/8X$</td> </tr> </tbody> </table> <p>* X=LCD SIDE WIDTH t=GLASS THICKNESS</p>	a	b	c	$\leq t$	$\leq 0.5\text{mm}$	$\leq 1/8X$					
a	b	c										
$\leq t$	$\leq 0.5\text{mm}$	$\leq 1/8X$										
	<table border="1" data-bbox="935 1435 1458 1496"> <thead> <tr> <th>a</th> <th>b</th> <th>c</th> </tr> </thead> <tbody> <tr> <td>$\leq t$</td> <td>$\leq 1/8X$</td> <td>$\leq L$</td> </tr> </tbody> </table> <p>*X=LCD SIDE WIDTH t = GLASS THICKNESS L=ELECTRODE PAD LENGTH</p> <p>①IF GLASS CHIPPING THE ITO TERMINAL, OVER 2/3 OF THE ITO MUST REMAIN AND BE, INSPECTED ACCORDING TO ELECTRODE TERMINAL SPECIFICATIONS</p> <p>②IF THE PRODUCT WILL BE HEAT SEALED BY THE CUSTOMER, THE ALIGNMENT MARK MUST NOT BE DAMAGED</p>	a	b	c	$\leq t$	$\leq 1/8X$	$\leq L$					
a	b	c										
$\leq t$	$\leq 1/8X$	$\leq L$										

12.4 RELIABILITY TEST

12.4.1 STANDARD SPECIFICATIONS FOR RELIABILITY OF LCD MODULE

NO	ITEM	DESCRIPTION
1	High temperature operation	The sample should be allowed to stand at +70°C for 240 hrs
2	Low temperature operation	The sample should be allowed to stand at -20°C for 240 hrs
3	High temperature storage	The sample should be allowed to stand at +80°C for 240 hrs
4	Low temperature storage	The sample should be allowed to stand at -30°C for 240 hrs
5	High temp / humidity test storage	The sample should be allowed to stand at 60°C , 90% RH 240 hrs
6	Thermal shock (not operated)	The sample should be allowed to stand the following 10 cycles of operation: -40°C for 30 minutes ~ +85°C for 30 minutes
7	ESD (Electrostatic Discharge) (not operated)	AIR DISCHARGE ± 12KV CONTACT DISCHARGE ± 8KV

NOTE (1) : THE TEST SAMPLES HAVE RECOVERY TIME FOR 2 HOURS AT ROOM TEMPERATURE BEFORE THE FUNCTION CHECK. IN THE STANDARD CONDITIONS, THERE IS NO DISPLAY FUNCTION NG ISSUE OCCURRED.

12.5 TESTING CONDITIONS AND INSPECTION CRITERIA

For the final test the testing sample must be stored at room temperature for 24 hours, after the tests listed in table 12.5 , standard specifications for reliability have been executed in order to ensure stability .

NO	ITEM	TEST MODEL	INSPECTION CRITERIA
1	Current consumption	Refer To Specification	The current consumption should conform to the product specification.
2	Contrast	Refer TO Specification	After the tests have been executed, the contrast must be larger than half of its initial value prior to the tests.
3	Appearance	Visual inspection	Defect free

12.6 OPERATION

- 12.6.1 Do not connect or disconnect modules to or from the main system while power is being supplied .
- 12.6.2 Use the module within specified temperature ; lower temperature causes the retardation of blinking speed of the display ; higher temperature makes overall display discolor . When the temperature returns to normality , the display will operate normally .
- 12.6.3 Adjust the LC driving voltage to obtain the optimum contrast .
- 12.6.4 Power On Sequence input signals should not be supplied to LCD module before power supply voltage is applied and reaches the specified value . If above sequence is not followed , CMOS LSIs of LCD modules may be damaged due to latch - up problem .
- 12.6.5 Not allowed to inflict any external stress and to cause any mechanical interference on the bending area of FPC during the tail bending backwards!
Do NOT stress FPC and IC on the Module!

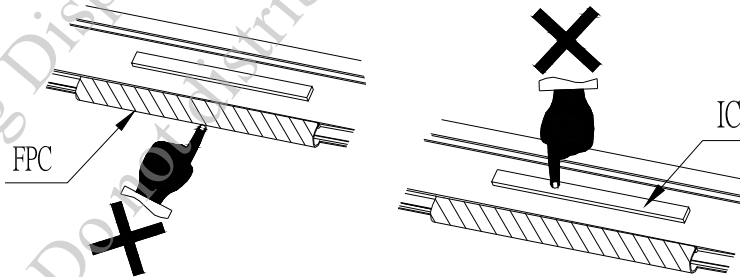

12.7 NOTICE

- 12.7.1 Use a grounded soldering iron when soldering connector I/O terminals . For soldering or repairing , take precaution against the temperature of the soldering iron and the soldering time to prevent peeling off the through-hole-pad .
- 12.7.2 Do not disassemble . EDT shall not be held responsible if the module is disassembled and upon the reassembly the module failed .
- 12.7.3 Do not charge static electricity , as the circuit of this module contains CMOS LSIs. A workman's body should always be static-protected by use of an ESD STRAP . Working clothes for such personnel should be of static-protected material .
- 12.7.4 Always ground the electrically-powered driver before using it to install the LCD module. While cleaning the work station by vacuum cleaner, do not bring the sucking mouth near the module ; static electricity of the electrically-powered driver or the vacuum cleaner may destroy the module .
- 12.7.5 Don't give external shock.
- 12.7.6 Don't apply excessive force on the surface.
- 12.7.7 Liquid in LCD is hazardous substance. Must not lick and swallow. When the liquid is attach to your, skin, cloth etc. Wash it out thoroughly and immediately.
- 12.7.8 Don't operate it above the absolute maximum rating.
- 12.7.9 Storage in a clean environment, free from dust, active gas, and solvent.
- 12.7.10 Store without any physical load.
- 12.7.11 Rewiring: no more than 3 times.