

PicoMOD4

Single Board Computer with Samsung ARM9-CPU



Characteristics

- Samsung S3C2450 with 533MHz
- 64MB Flash, 64MB mobile DDR-RAM
- LCD-interface to STN-, CSTN- and TFT-LCDs up to SVGA-resolution
- Ethernet 10/100MBit
- 3x Serial (RS232 with 3,3V-level)
- 1x USB2.0 Device (High Speed)
- 1x USB1.1 Host
- 1x CAN2.0 / 1x I2C / 1x SPI
- external SD- and CF-Card-Slot
- max. 64 I/O-lines
- Audio / Touchcontroller / Matrixkeyboard
- Windows CE 6.0 / Linux installed incl. license
- 3,3V low power design (<2W at operation)

Description

This compact (80mm x 50mm) and inexpensive Single Board Computer PicoMOD4 is especially suited for mobile devices as well as for stationary devices in industrial (-20°C to +85°C) and medical applications. The core of the PicoMOD4 is a Samsung ARM9 CPU with 533MHz. 64MB flash and 64MB RAM are available, optional even more. And it is equally well equipped on the periphery side: 3x serial, 2x USB2.0 (high speed), I²C, SPI, I/O, Audio, CAN2.0, Ethernet, SD and CF card and touch controller. In addition, the PicoMOD4 offers the same flexible display interface as is typical with F&S boards. All common STN, CSTN and TFT displays up to 800x600 (SVGA) can be connected. The power supply of the PicoMOD4 is 3.3V. Naturally for all these interfaces there are software drivers included in the integrated operating system, Windows CE or Linux. A robust 140-pin connector is used to plug the PicoMOD4 onto the carrier board of the application.

On-Board Operating System



Reuse your Windows know-how with Windows Embedded CE 6.0! Implement your software with Visual Studio .NET in the programming languages C, C++, C# or VB.NET. Keep contact to the future with TCP/IP, DCOM and XML.



The Linux Evaluation Board Support Package (BSP) is already supplied with the starterkit. This package supports all basic interfaces and even allows development on a Windows PC. The additionally available Professional BSP offers the full capacity of the PicoMOD4 and development integration into the Eclipse IDE.

Full-Scale Representation

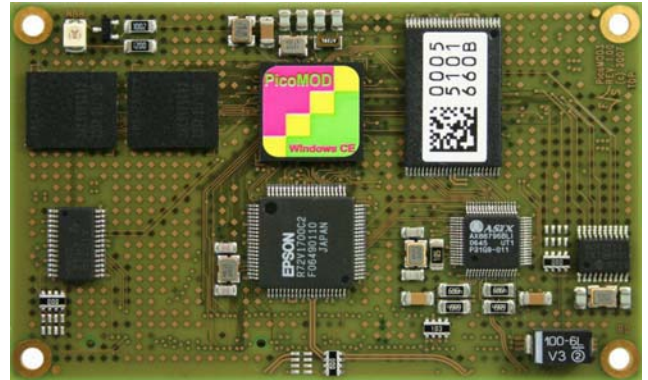

Block diagram

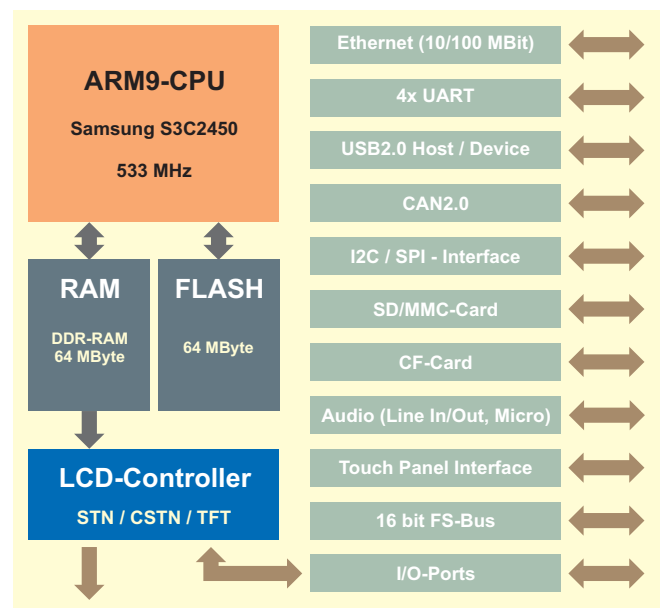

Starter-kit

For a fast and straightforward development start there is an all-purpose starter-kit available for Windows CE and Linux. This kit consists of a PicoMOD4, an intermediate board, a base board, several cables, memory media, documentation and software. Unpack the kit and supply power, this is how straightforward the project start can be. And if you take our 4-hour workshop, where you learn all about the setting-up of the PicoMOD4, it's even more simple. For the software development under Windows CE, the Microsoft Visual Studio .NET is required (not included). For Linux development, the Evaluation Version of the Board Support Package is included.

Connector assignment

J1 - System-Connector													
1	I/O64 (SPI CS)	21	I/O5 (COM1 TxD)	41	I/O14	61	I/O32 (LCD VD0)	81	I/O52 (LCD VM)	101	A2 (Address 2)	121	D11 (Data 11)
2	I/O65 (SPI CLK)	22	I/O4 (COM1 RxD)	42	I/O13	62	GND (System Ground)	82	I/O51 (LCD VFRAME)	102	A3 (Address 3)	122	D12 (Data 12)
3	I/O66 (SPI MISO)	23	I/O7 (COM3 TxD)	43	I/O16	63	I/O34 (LCD VD2)	83	GND (System Ground)	103	A4 (Address 4)	123	D13 (Data 13)
4	I/O67 (SPI MOSI)	24	I/O6 (COM3 RxD)	44	I/O15	64	I/O33 (LCD VD1)	84	GND (System Ground)	104	A5 (Address 5)	124	D14 (Data 14)
5	CAN-TX	25	DN1 (USB Device -)	45	I/O18 (SD-CLK)	65	I/O36 (LCD VD4)	85	GND (System Ground)	105	A6 (Address 6)	125	D15 (Data 15)
6	CAN-RX	26	DN0 (USB Host -)	46	I/O17	66	I/O35 (LCD VD3)	86	I/O53 (LCD VCLK)	106	A7 (Address 7)	126	I/O75 (CF Power En.)
7	RX- (Ethernet)	27	DP1 (USB Device +)	47	I/O20 (SD-DAT0)	67	I/O38 (LCD VD6)	87	I/O70 (CF nCD)	107	A8 (Address 8)	127	CS5 (FS-Bus CS)
8	TX- (Ethernet)	28	DP0 (USB Host +)	48	I/O19 (SD-CMD)	68	I/O37 (LCD VD5)	88	I/O71 (CF nRQ)	108	A9 (Address 9)	128	ETH-ACT (Ethernet)
9	RX+ (Ethernet)	29	I/O9	49	I/O22 (SD-DAT2)	69	I/O40 (LCD VD12)	89	nWAIT (CF nWAIT)	109	A10 (Address 10)	129	STA1 (Status 1)
10	TX+ (Ethernet)	30	I/O8 (USB Host Pow)	50	I/O21 (SD-DAT1)	70	I/O39 (LCD VD7)	90	I/O72 (CF nPACK)	110	D0 (Data 0)	130	STA2 (Status 2)
11	+3,3V (Power Supply)	31	I/O11 (I2C-SDA)	51	I/O24 (SD-Detect)	71	I/O42 (LCD VD14)	91	CS2 (CF CS2)	111	D1 (Data 1)	131	LOUT (Audio L. Out)
12	+3,3V (Power Supply)	32	I/O10 (USB Dev Det)	52	I/O23 (SD-DAT3)	72	I/O41 (LCD VD13)	92	CS3 (CF CS3)	112	D2 (Data 2)	132	ROUT (Audio R. Out)
13	GND (System Ground)	33	TCK (JTAG)	53	I/O26 (SD-Write Prot.)	73	I/O44 (LCD VD18)	93	I/O73 (CF REG)	113	D3 (Data 3)	133	LN (Audio Left In)
14	GND (System Ground)	34	I/O12 (I2C-SCL)	54	I/O25 (SD-Power En.)	74	I/O43 (LCD VD15)	94	nOE_CF (CF nOE)	114	D4 (Data 4)	134	RIN (Audio Right In)
15	nPONRES (Res CPU)	35	TDO (JTAG)	55	I/O28 (LCD DEN)	75	I/O46 (LCD VD20)	95	nWE_CF (CF nWE)	115	D5 (Data 5)	135	MICIN (Micro In)
16	VBAT (RTC Supply)	36	TDI (JTAG)	56	I/O27 (LCD Enable)	76	I/O45 (LCD VD19)	96	nOE	116	D6 (Data 6)	136	MICBIAS (Micro Bias)
17	I/O1 (COM2 TxD)	37	nTRST (JTAG)	57	I/O30 (LCD VCFL On)	77	I/O48 (LCD VD22)	97	nWE	117	D7 (Data 7)	137	X+ (Touch X+)
18	I/O0 (COM2 RxD)	38	TMS (JTAG)	58	I/O29 (LCD VLCD On)	78	I/O47 (LCD VD21)	98	I/O74 (CF RESET)	118	D8 (Data 8)	138	X- (Touch X-)
19	I/O3 (COM2 RTS)	39	GND (System Ground)	59	GND (System Ground)	79	I/O50 (LCD VLINE)	99	A0 (Address 0)	119	D9 (Data 9)	139	Y+ (Touch Y+)
20	I/O2 (COM2 CTS)	40	GND (System Ground)	60	I/O31 (LCD VEEK)	80	I/O49 (LCD VD23)	100	A1 (Address 1)	120	D10 (Data 10)	140	Y- (Touch Y-)

LCD-connection

Pico-MOD4	Mono STN		Color STN		TFT	
	4 bit	8 bit	Single	Dual	12 bit	18 bit
VD0	D0	D4 (UD0)	D0	UD0		G0
VD1	D1	D5 (UD1)	D1	UD1		G1
VD2	D2	D6 (UD2)	D2	UD2		B0
VD3	D3	D7 (UD3)	D3	UD3		B1
VD4		D0 (LD0)	D4	LD0	B0	B2
VD5		D1 (LD1)	D5	LD1	B1	B3
VD6		D2 (LD2)	D6	LD2	B2	B4
VD7		D3 (LD3)	D7	LD3	B3	B5
VD12					G0	G2
VD13					G1	G3
VD14					G2	G4
VD15					G3	G5
VD18						R0
VD19						R1
VD20					R0	R2
VD21					R1	R3
VD22					R2	R4
VD23					R3	R5
VCLK	CL2	CL2	CP		DCLK	DCLK
VLINE	CL1	CL1	LOAD		HSYNC	HSYNC
VFRAME	FLM	FLM	FRM		VSYNC	VSYNC
VM	M	M	M		DE	DE
DEN	nDISPOFF	nDISPOFF	nDISP		---	---

Technical data

Power supply:	+3,3V _{DC} / ±5%
Power consumption:	<400mA
Digital I/O:	max. 64 I/O-port lines (alternative with interfaces allocated)
Touch-screen:	4 Draht, analog resestiv
Interfaces:	1x Ethernet 10/100 MBit 3x Serial (1x with RTS/CTS, all with 3,3V-level) 1x USB2.0 Host (High Speed) optional 1x USB1.1 Host und USB2.0 Device (High Speed) 1x CAN2.0 1x I2C 1x SPI (optional) Audio (Line in/out, Micro in, all analogue) 1x SD-Card-Slot (external) 1x Compact Flash Slot (external) 1x FS-Bus interface
LCD-interface:	STN: up to 640 x 480 pixel, single/dual scan 16 shades of grey CSTN: up to 640 x 480 pixel, single/dual scan 16/256 colours of 65536 TFT: up to 800 x 600 pixel 256/65536 colours
RAM:	64 MByte mobile DDR-RAM
Program memory:	64 MByte Flash
Processor:	Samsung S3C2450-533
Temperature range:	-20°C .. 85°C
Dimension:	80mm x 50mm x 9mm (l x w x h)
Weight:	ca. 20 gr

Standard versions / Order notation

PicoMOD4-ANC-WCE

64MB DDR-RAM, 64MB Flash, Audio, Ethernet, CAN, USB, Windows CE 6.0

PicoMOD4-ANC-LIN

64MB DDR-RAM, 64MB Flash, Audio, Ethernet, CAN, USB, Embedded Linux

PicoMOD4-SKIT-WCE

Starter-kit with PicoMOD4-ANC-WCE, intermediate board, base board, cables, SD-Card, USB-Stick, SDK, dokumentation

PicoMOD4-SKIT-LIN

Starter-kit with PicoMOD4-ANC-WCE, intermediate board, base board, cables, SD-Card, USB-Stick, SDK, dokumentation

NetDCU-WS

Quick-start-workshop for PicoMOD and Windows Embedded CE

Order key

PicoMOD4-64D64FANCU-WCE

RAM DDR-RAM	Flash	Audio	Ethernet	CAN	USB High Speed	System
blank 64 MByte	blank 64 MByte	blank no Audio	blank no Ethernet	blank no CAN	blank no USB	WCE Windows CE 6.0
		A Audio	N Ethernet	C CAN2.0	U USB2.0	LIN Embedded Linux

Attention:
Special versions only for order quantities of at least 1000 parts!